

8-10 NEW MCLEAN ST, EDGECLIFF

Qualitative Environmental Wind Assessment

Prepared for:

Mount St 4 Pty Ltd
Level 29, 2 Chifley Plaza,
Sydney 2000

SLR Ref: 610.31197-R01
Version No: -v1.0
July 2023



PREPARED BY

SLR Consulting Australia Pty Ltd
ABN 29 001 584 612
Tenancy 202 Submarine School, Sub Base Platypus, 120 High Street
North Sydney NSW 2060 Australia

T: +61 2 9427 8100
E: sydney@slrconsulting.com www.slrconsulting.com

BASIS OF REPORT

This report has been prepared by SLR Consulting Australia Pty Ltd (SLR) with all reasonable skill, care and diligence, and taking account of the timescale and resources allocated to it by agreement with Mount St 4 Pty Ltd (the Client). Information reported herein is based on the interpretation of data collected, which has been accepted in good faith as being accurate and valid.

This report is for the exclusive use of the Client. No warranties or guarantees are expressed or should be inferred by any third parties. This report may not be relied upon by other parties without written consent from SLR.

SLR disclaims any responsibility to the Client and others in respect of any matters outside the agreed scope of the work.

DOCUMENT CONTROL

Reference	Date	Prepared	Checked	Authorised
610.31039-R01-v1.0	26 July 2023	Mark Hobday	Dr Neihad Al-Khalidy	Dr Neihad Al-Khalidy

EXECUTIVE SUMMARY

SLR Consulting Pty Ltd (SLR) has been engaged by Mount St 4 Pty Ltd to undertake a qualitative wind assessment of the proposed up to 23-storey at 8-10 New McLean St, Edgecliff, mixed use development. This assessment will form part of the application to Woollahra Municipal Council.

The “near-field” built environment comprises a combination of medium to high rise residential and commercial buildings to the south and west, with a waterfront area to the east, and blocks of low-rise residential houses to the north and northeast.

Prevailing wind directions of interest in Sydney are from northeast, south, southeast and west quadrants. Their seasonal variation is described in **Section 2** of this report.

Existing Wind Environment

Existing street level wind conditions in the vicinity of the site could be close to or greater than 16 m/s “walking comfort” criterion for some prevailing wind directions, resulting from channelling of winds along aligning streets.

Future Wind Environment

In terms of the future wind environment with the proposed development, the following features of the development are noted as being of most significance:

- The winds along the surrounding footpaths should remain at similar levels or improve providing appropriate landscaping is employed as proposed.
- Retention of horizontal wind breaks are recommended over building entries, to protect against potential downwash from the high-level development. These breaks can be in the form of landscaping or construction features. Furthermore, pergolas are recommended above seating areas in the communal open spaces.
- Vertical windbreaks are recommended to the the communal open space areas.
- Retention of all proposed landscaping be retained. All landscaping is to be of an evergreen species.

The above analysis has been made on the basis of our best engineering judgment and on the experience gained from scale model wind tunnel testing or computational fluid dynamics analysis of a range of developments. The conclusions of this SLR report will be quantified using wind tunnel testing.

CONTENTS

1	INTRODUCTION	6
1.1	Development Description	7
1.2	Surrounding Built Environment	8
2	SYDNEY'S WIND CLIMATE	9
2.1	Annual and Seasonal Regional Variations.....	9
2.2	Representative Winds for Edgecliff	10
2.3	Wind Exposure at the Site – the “Local” Wind Environment	11
3	BUILDING-WIND INTERACTION – GENERAL OBSERVATIONS.....	11
4	WIND ACCEPTABILITY CRITERIA	13
4.1	Standard Local Government Criteria	13
4.2	Application of Wind Criteria	13
5	WIND IMPACT OF THE PROPOSED DEVELOPMENT.....	14
5.1	Existing Winds – Wind Impact and Effects	14
5.2	Future Winds – Predicted Wind Flow Patterns	14
5.2.1.1	Northeast Winds	23
5.2.1.2	South and Southeast Winds	26
5.2.1.3	Westerly Winds	29
6	WIND AMELIORATION RECOMMENDATIONS	32
7	CONCLUSION.....	44

DOCUMENT REFERENCES

TABLES

Table 1	Standard Local Government Wind Acceptability Criteria	13
Table 2	Recommended Wind Mitigation	32

CONTENTS

FIGURES

Figure 1	Site Location	6
Figure 2	Typical Layout Plan.....	7
Figure 3	Built Environment	8
Figure 4	Annual Wind Roses for Sydney (KS) Airport (BoM Data)	9
Figure 5	Seasonal Variation of Wind Speeds Expected at Edgecliff	10
Figure 6	Wind Flow Patterns Past Regular Shaped Buildings	11
Figure 7	Wind Flow Patterns Past Groups of Buildings.....	12
Figure 8	Areas of Interest – Lower Ground.....	15
Figure 9	Areas of Interest – Lower Ground.....	16
Figure 10	Areas of Interest – Levels 1	17
Figure 11	Areas of Interest – Level 03.....	18
Figure 12	Areas of Interest – Level 04.....	19
Figure 13	Areas of Interest – Level 05.....	20
Figure 14	Areas of Interest – Level 08.....	21
Figure 15	Areas of Interest – Level 19.....	22
Figure 16	Mitigation Recommendations – Ground Level	38
Figure 17	Mitigation Recommendations – Levels 3	39
Figure 18	Mitigation Recommendations – Level 04.....	40
Figure 19	Mitigation Recommendations – Level 05.....	40
Figure 20	Mitigation Recommendations – Level 08.....	41
Figure 21	Mitigation Recommendations – Level 19.....	43

APPENDICES

Appendix A Sydney Wind Roses

1 Introduction

SLR Consulting Pty Ltd (SLR) has been engaged by Mount St 4 Pty Ltd to undertake a qualitative wind assessment of the proposed up to 23-storey 8-10 New McLean St, Edgecliff, mixed use development. This assessment will form part of the application to Woollahra Municipal Council.

The development is bounded by New McLean Street to the north and Glenmore Road to the west, with mid-rise buildings surrounding the development to the east and west. The site location and surrounds are shown in Error! Reference source not found. below.

Figure 1 Site Location

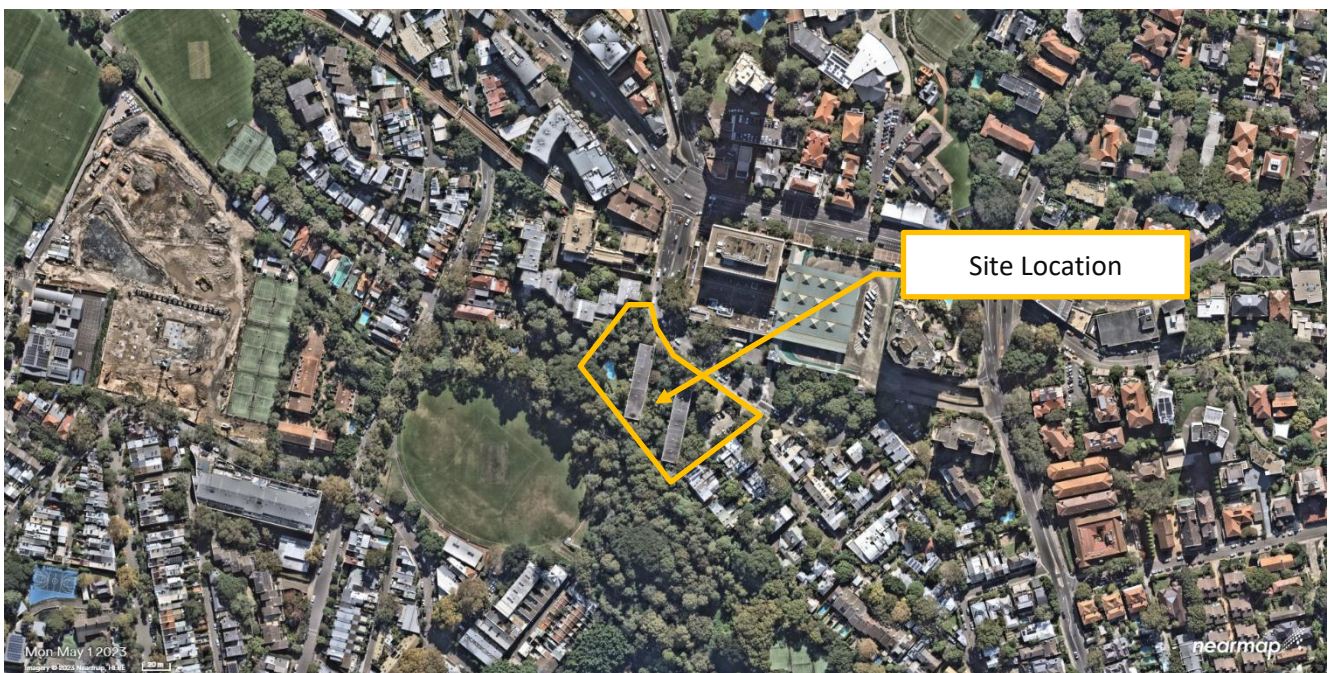

Image: Nearmap, 23 May 2023

1.1 Development Description

The development site is situated at 8-10 New McLean Street, Edgecliff which is within the Woollahra Municipal Council.

The proposed development will comprise of a 23-storey high building. Based on the proposed architectural drawings the site will include the following:

- 4 levels of basement car parking with residential apartments on basement 1.
- Lower ground level with community areas, residential apartments, and car parking.
- Upper ground level with commercial and retail areas, lobbies, and residential apartments.
- Level 01 to 22 with residential apartments.
- Roof communal open spaces on levels 1, 3, 4, 5, 8 and 19.

Figure 2 Typical Layout Plan



Image: Proposed Development.

1.2 Surrounding Built Environment

“Near Field”

The “near-field” built environment comprises a combination of low to mid rise residential and commercial buildings to the north, east and northwest. To the south of the development there are large foliated areas before the large open space of Trumper Oval – refer **Figure 3**. It is expected that the building will receive some shielding in all directions around the ground and lower levels, but upper levels will be exposed to higher level winds.

“Far Field”

The “far-field” built environment comprises the same mix of typically low to mid rise residential areas and commercial/industrial buildings towards the north, east and west, with scattered high rise residential buildings on the north and east. Further towards the west there are some open spaces and parklands areas.

The surrounding topography has a slight incline towards the northeast but there are no significant topography features (hills, ridges, escarpments, etc) influencing local wind speeds.

Figure 3 Built Environment



2 SYDNEY'S WIND CLIMATE

The data of interest in this study are the mean hourly wind speeds and largest gusts experienced throughout the year (especially higher, less frequent winds), how these winds vary with azimuth, and the seasonal break-up of winds into the primary Sydney Region wind seasons.

2.1 Annual and Seasonal Regional Variations

Key characteristics of Sydney's Regional Wind Climate are illustrated in two representative wind roses shown in **Figure 4**, taken from Bureau of Meteorology (BoM) data recorded during the period 1999-2017 at Sydney (Kingsford Smith) Airport. A review of the associated seasonal wind roses (refer **Appendix A**) shows that Sydney is affected by two primary wind seasons with relatively short (1-2 month) transition periods in between:

- Summer winds occur mainly from the northeast, southeast and south. While northeast winds are the more common prevailing wind direction (occurring typically as offshore land-sea breezes), southeast and southerly winds generally provide the strongest gusts during summer. Northeast winds (as sea breezes) and stronger southerly winds (eg "East Coast Lows" and "Southerly Busters") have a greater impact along the coastline. Inland, these systems lose strength and have altered wind direction characteristics.
- Winter/Early Spring winds occur mainly from west quadrants and to a lesser extent from the south. West quadrant winds provide the strongest winds during winter and in fact for the whole year, particularly at locations away from the coast.

Figure 4 Annual Wind Roses for Sydney (KS) Airport (BoM Data)

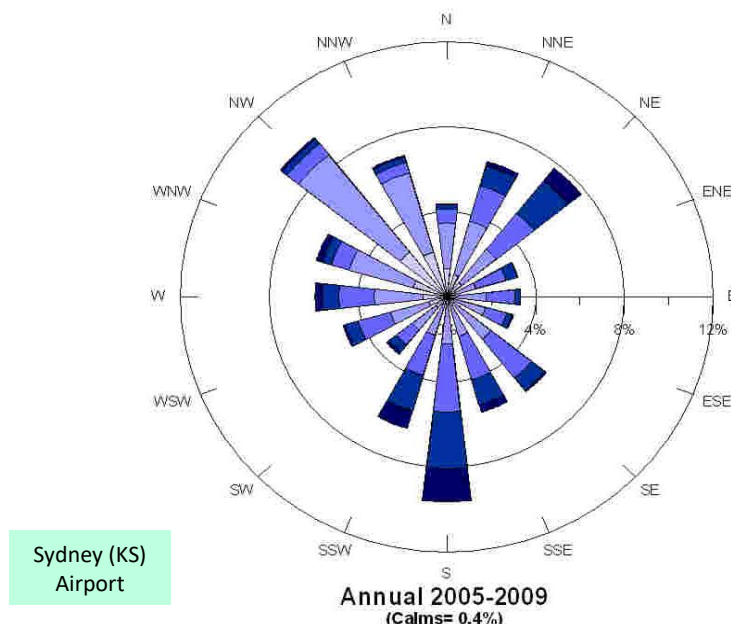

2.2 Representative Winds for Edgecliff

SLR has carried out a detailed study of Sydney Basin wind speeds using continuous records of wind speed and direction measured at the Bureau of Meteorology's (BoM) Sydney weather stations. Particular emphasis was given to weather stations with a "clean" surrounding exposure, ie. stations such as Sydney (Kingsford Smith) Airport can be found in:

- SLR Technical Note: "9300-TN-CW&E-v2.0 Sydney Region Design Winds", March 2018.

Figure 5 Seasonal Variation of Wind Speeds Expected at Edgecliff

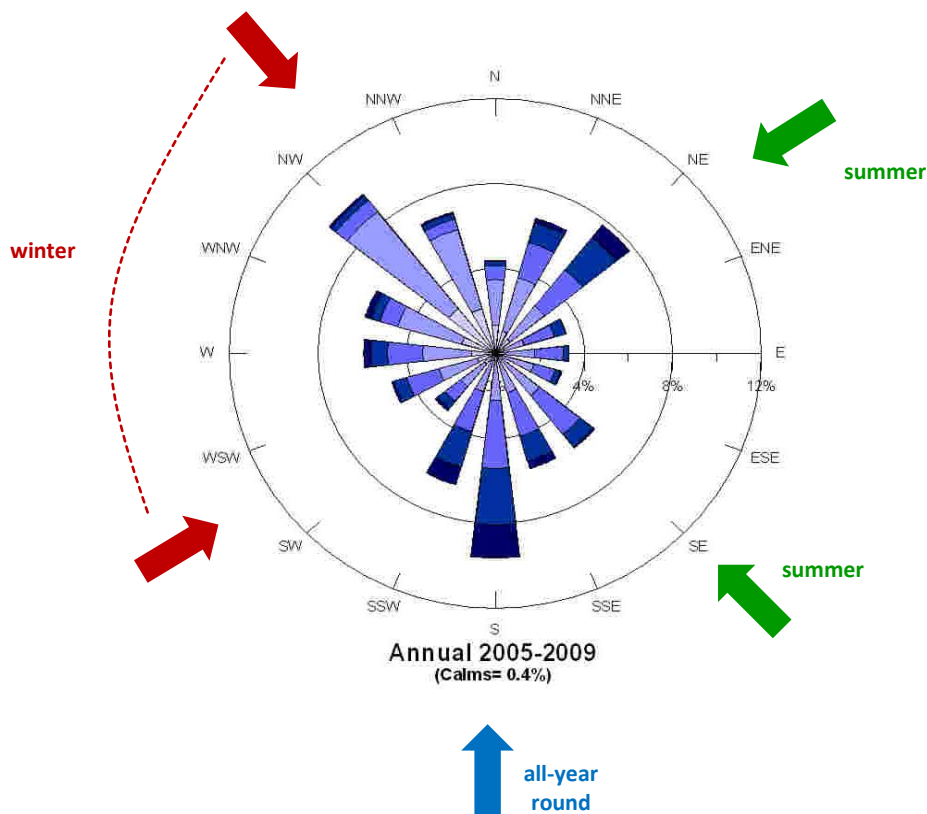

2.3 Wind Exposure at the Site – the “Local” Wind Environment

Close to the ground, the “regional” wind patterns described above are affected by the local terrain, topography and built environment, all of which influence the “local” wind environment.

- As noted in **Section 1.2**, the far field environment currently comprises of a mix of typically medium to high rise residential commercial buildings to the north and northwest. Blocks of low-rise residential houses towards the east and southeast with a large open space to the south of the development which is surrounded by large foliage.
- It is expected that the building will receive some shielding in all directions around the ground and lower levels, but upper levels will be exposed to higher level winds.

3 Building-wind interaction – general observations

The impact of wind flowing past buildings has well understood general impacts at ground level - refer **Figure 6**. In general, the taller the building, the more pronounced the impact on ground level winds.

- **Downwash winds “D”** are the winds which impact on the windward face of a building and are then deflected downwards to Ground Level in a vertical direction
- Accelerating **Shearflow winds “S”** are the winds which experience an acceleration as they pass by the building edges and roof as the wind flow moves around and past the building
- Concentrated adverse windflow can also be created when winds are accelerated by the negative pressure area at an undercroft (“U”) or through passages (“P”) at the base of buildings.

Figure 6 Wind Flow Patterns Past Regular Shaped Buildings

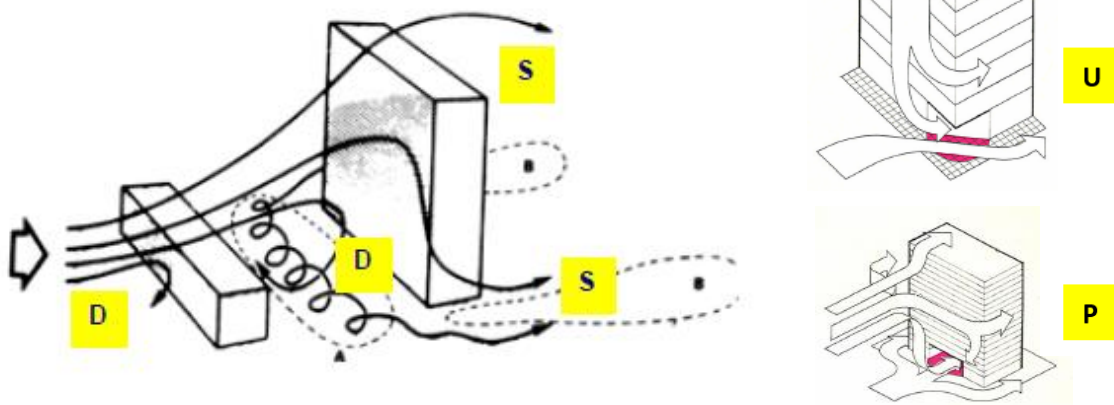

The grouping of buildings can also have an impact on surrounding pedestrian winds – refer **Figure 7**.

- **Channelling Effect winds “C”** result when there are rows of parallel buildings (especially taller ones) where the gaps in between the buildings line up with prevailing wind directions.
- **Venturi Effect winds “V”** result when wind flow is forced to pass between two converging buildings or groups of buildings with a resulting increase in flow.

Figure 7 Wind Flow Patterns Past Groups of Buildings

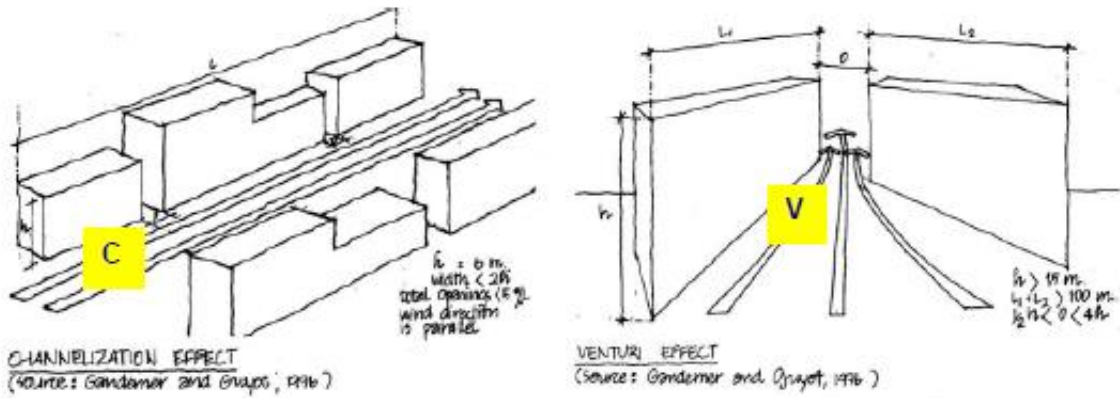

4 Wind Acceptability Criteria

4.1 Standard Local Government Criteria

The choice of suitable criteria for evaluating the acceptability of particular ground level conditions has been the subject of international research over the past few decades. One of the commonly accepted sets of acceptability criteria developed from this research, currently referenced by many Australian Local Government Development Control Plans, is summarised in **Table 1**. The limiting wind speed criteria in **Table 1** are based on the maximum wind gust occurring (on average) once per year.

Table 1 Standard Local Government Wind Acceptability Criteria

Type of Criteria	Limiting Gust Wind Speed Occurring Once Per Year	Activity Concerned
Safety	24 m/s	Knockdown in Isolated Areas
	23 m/s	Knockdown in Public Access Areas
Comfort	16 m/s	Comfortable Walking
	13 m/s	Standing, Waiting, Window Shopping
	10 m/s	Dining in Outdoor Restaurant

The primary objectives relating to the above wind impact criteria are as follows:

- The general objective is for annual 3-second gust wind speeds to remain at or below the so-called 16 m/s “Walking Comfort” criterion. Whilst this magnitude may appear somewhat arbitrary, its value represents a level of wind intensity above which the majority of the population would find unacceptable for comfortable walking on a regular basis at any particular location.
- In many urban locations, either because of exposure to open water conditions or because of street “canyon” effects, etc, the 16 m/s “Walking Comfort” level may already be currently exceeded. In such instances a new development should ideally not exacerbate existing adverse wind conditions and, wherever feasible and reasonable, ameliorate such conditions.
- It can be seen in **Table 1** that the recommended limiting wind speeds for spaces designed for activities such as seating, outdoor dining, etc., are lower (ie more stringent) than for “walking comfort”.

4.2 Application of Wind Criteria

The criteria provided in **Table 1** (especially in relation to Comfort) should not be viewed as “hard” numbers as the limiting values were generally derived from subjective assessments of wind acceptability. Such assessments have been found to vary considerably with the height, strength, age, etc., of the pedestrian concerned. A further factor for consideration is the extent of windy conditions, and some relaxation of the above criteria may be acceptable for small areas under investigation provided the general site satisfies the relevant criteria.

5 Wind Impact of the Proposed Development

5.1 Existing Winds – Wind Impact and Effects

Existing street level wind conditions in the vicinity of the site could be close to or greater than 16 m/s “walking comfort” criterion for some prevailing wind directions, resulting from channelling of winds along aligning streets. The surrounding built environment which consists of significant urban development to all orientations, offers some protection to the majority of wind directions.

Northeast Winds

Shielding to the immediate north of the site is generally medium-rise development. Given the existing density, there should be some shielding against winds occurring from the northeast. There remains some risk for channelling of winds along the channel between neighbouring buildings, resulting winds could exceed 16 m/s along associated pedestrian pathways.

Southerly Winds

Shielding to the immediate south of the site is generally large foliage and open space. Given the existing density, there should be limited shielding against winds occurring from the south. There remains some risk for channelling of winds along the channel between neighbouring buildings, resulting winds could exceed 16 m/s along ground areas.

Westerly Winds

Shielding to the immediate west of the site is generally low to medium rise developments. Given the existing density, there should be limited shielding against winds occurring from the west. There remains some risk for channelling of winds along the channel between neighbouring buildings, resulting winds could exceed 16 m/s along associated pedestrian pathways.

Upper-Level Winds

Existing upper-level wind conditions at the site are likely to exceed the 10 m/sec comfort criterion for some of the stronger prevailing wind directions (eg. south, southeast, southwest, and west).

5.2 Future Winds – Predicted Wind Flow Patterns

The following sections analyse the expected impacts of the proposed development on the pedestrian wind environment in the adjacent streetscape.

The wind impact of the proposed development is described by examining the impact of prevailing wind conditions on all public access areas of interest within and external to the development.

Areas of interest (i.e. surrounding footpaths, primary entry points, internal public access areas, seating and dining areas, etc) are identified in **Figures 8-11**.

Figure 8 Areas of Interest – Lower Ground

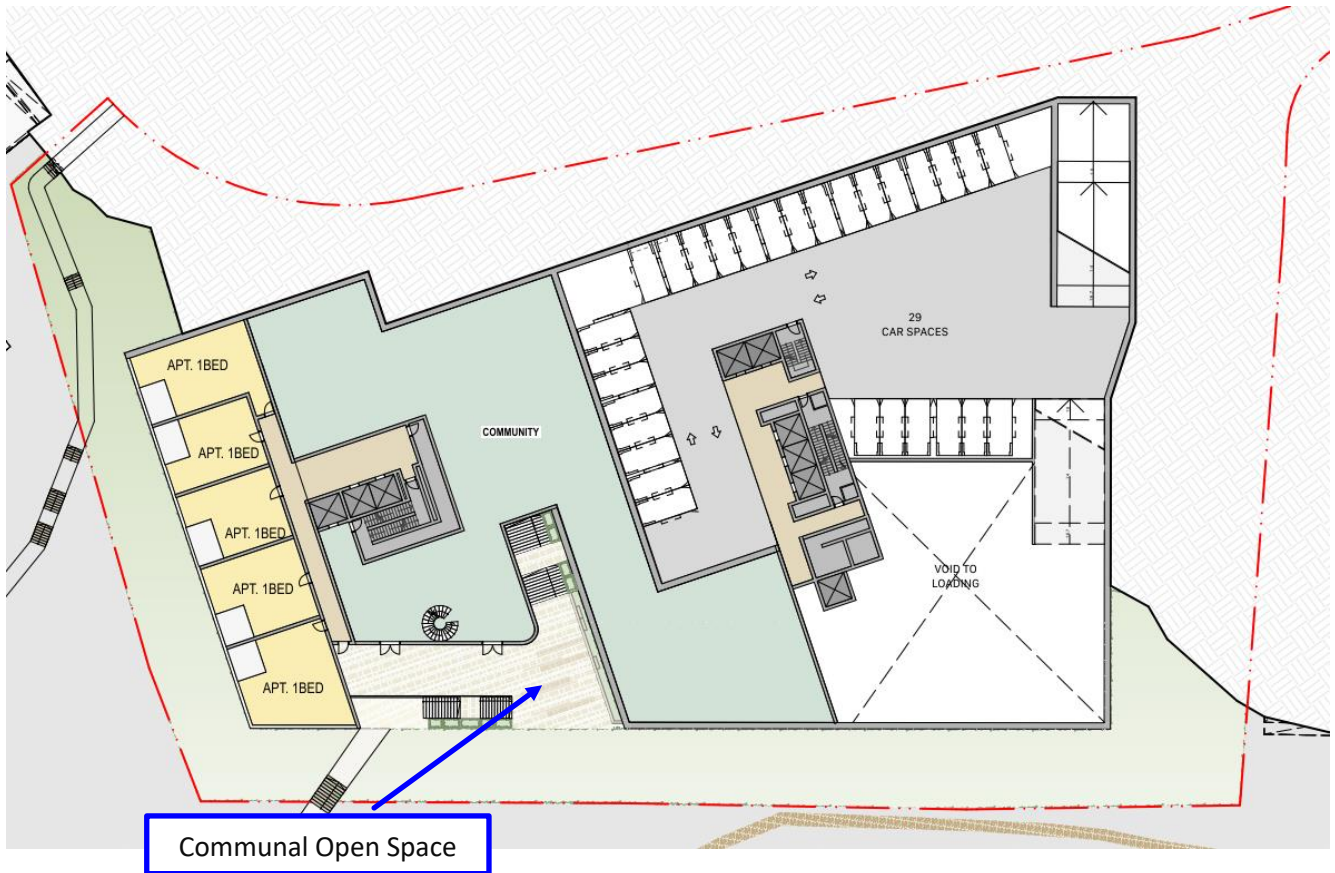

Figure 9 Areas of Interest – Lower Ground

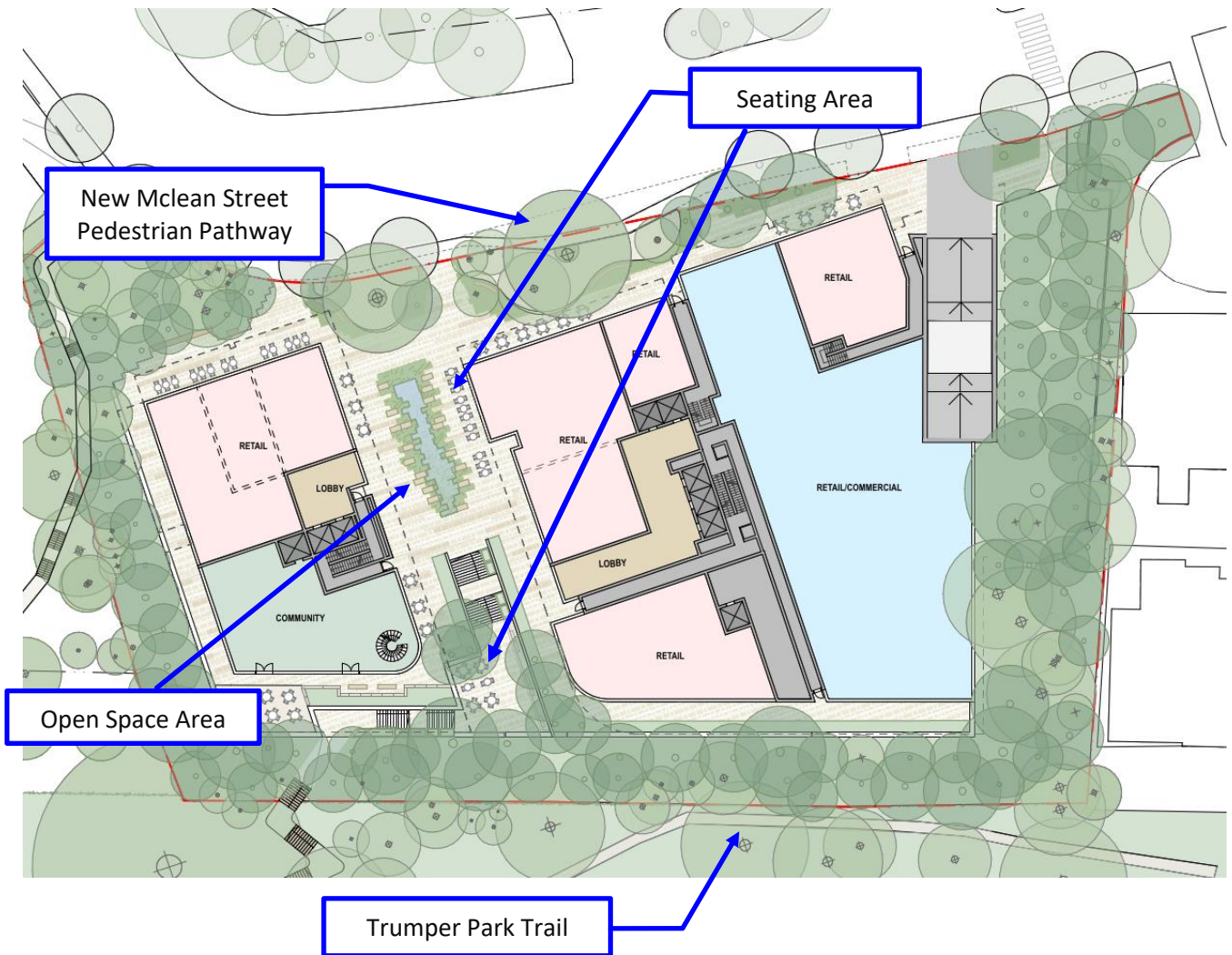

Figure 10 Areas of Interest – Levels 1

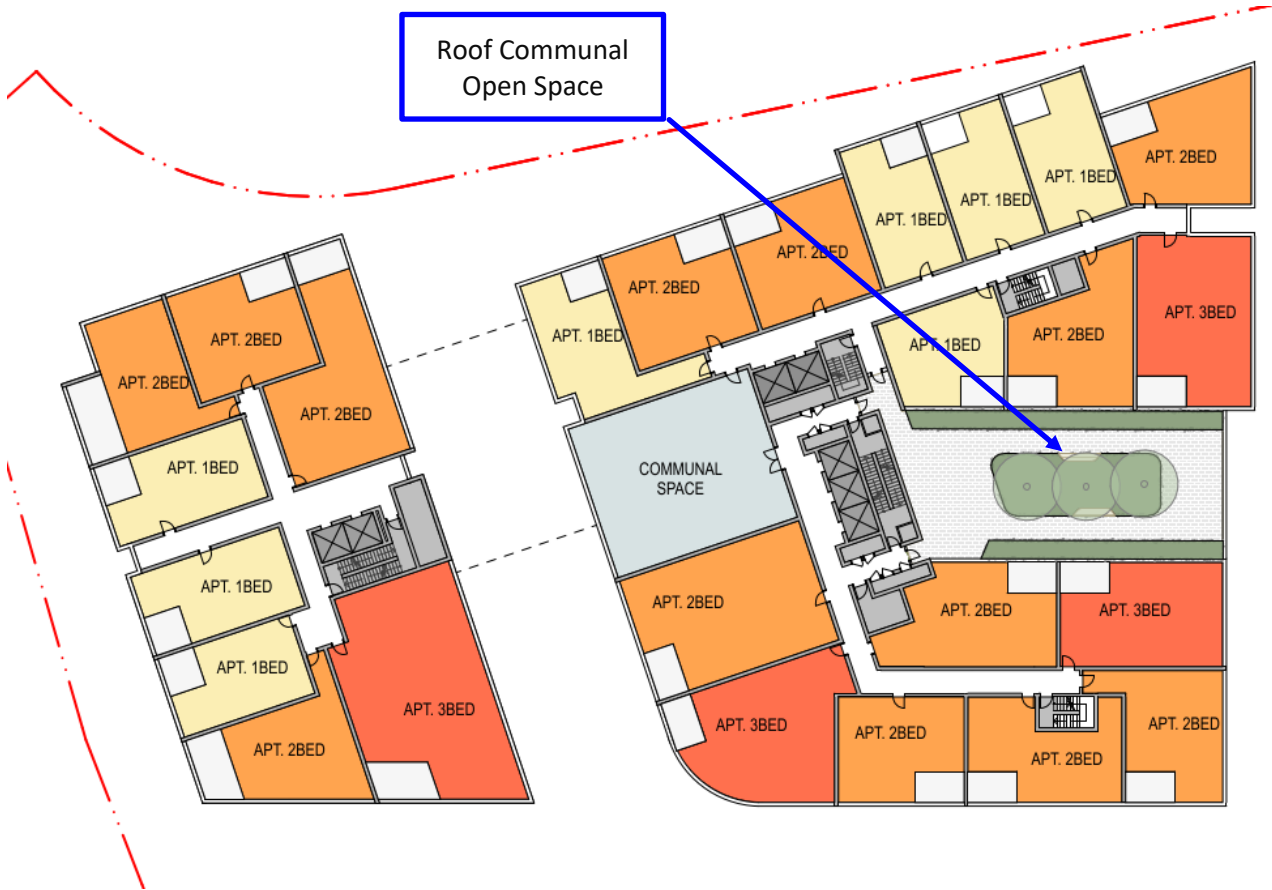

Figure 11 Areas of Interest – Level 03

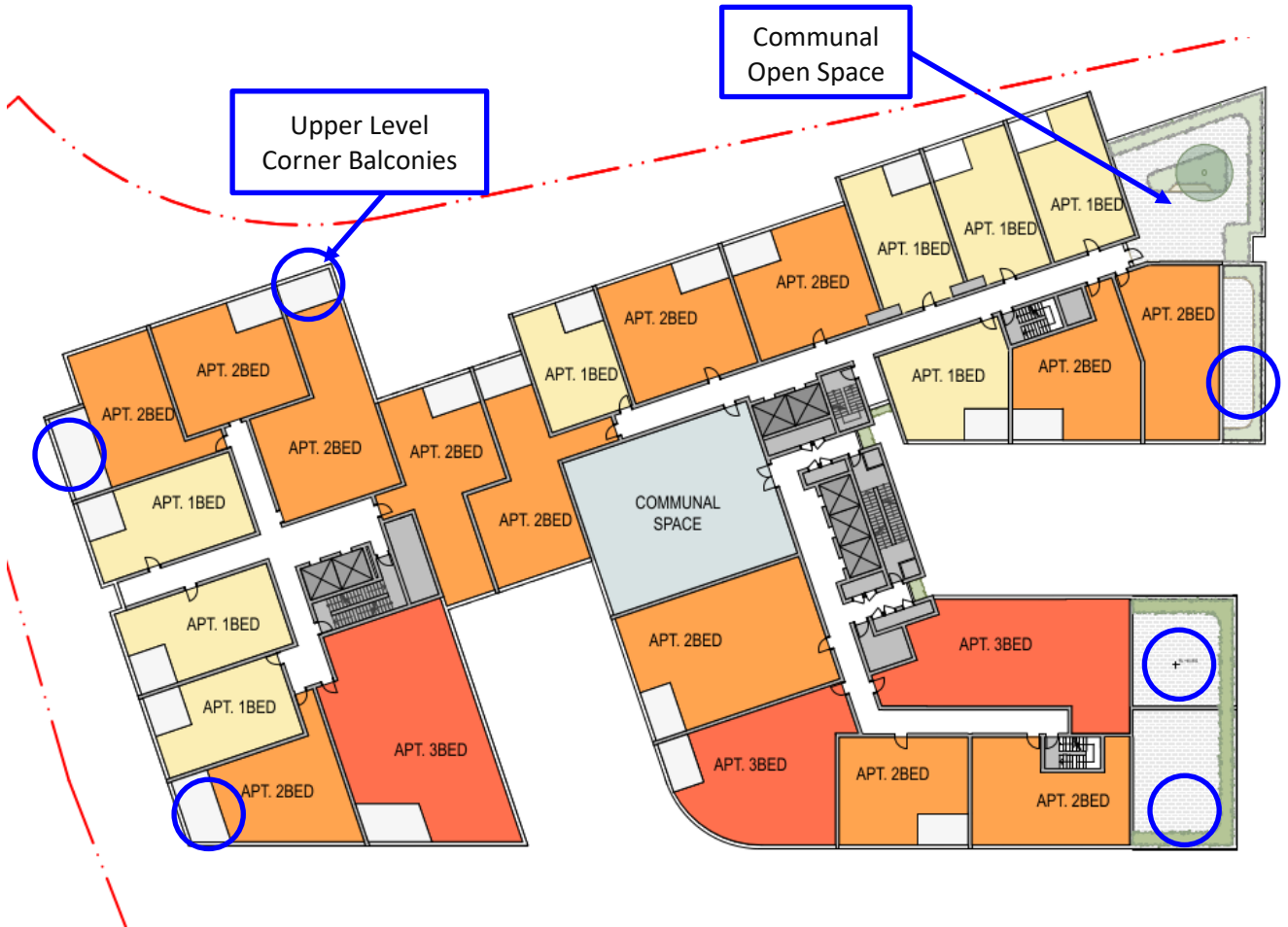

Figure 12 Areas of Interest – Level 04

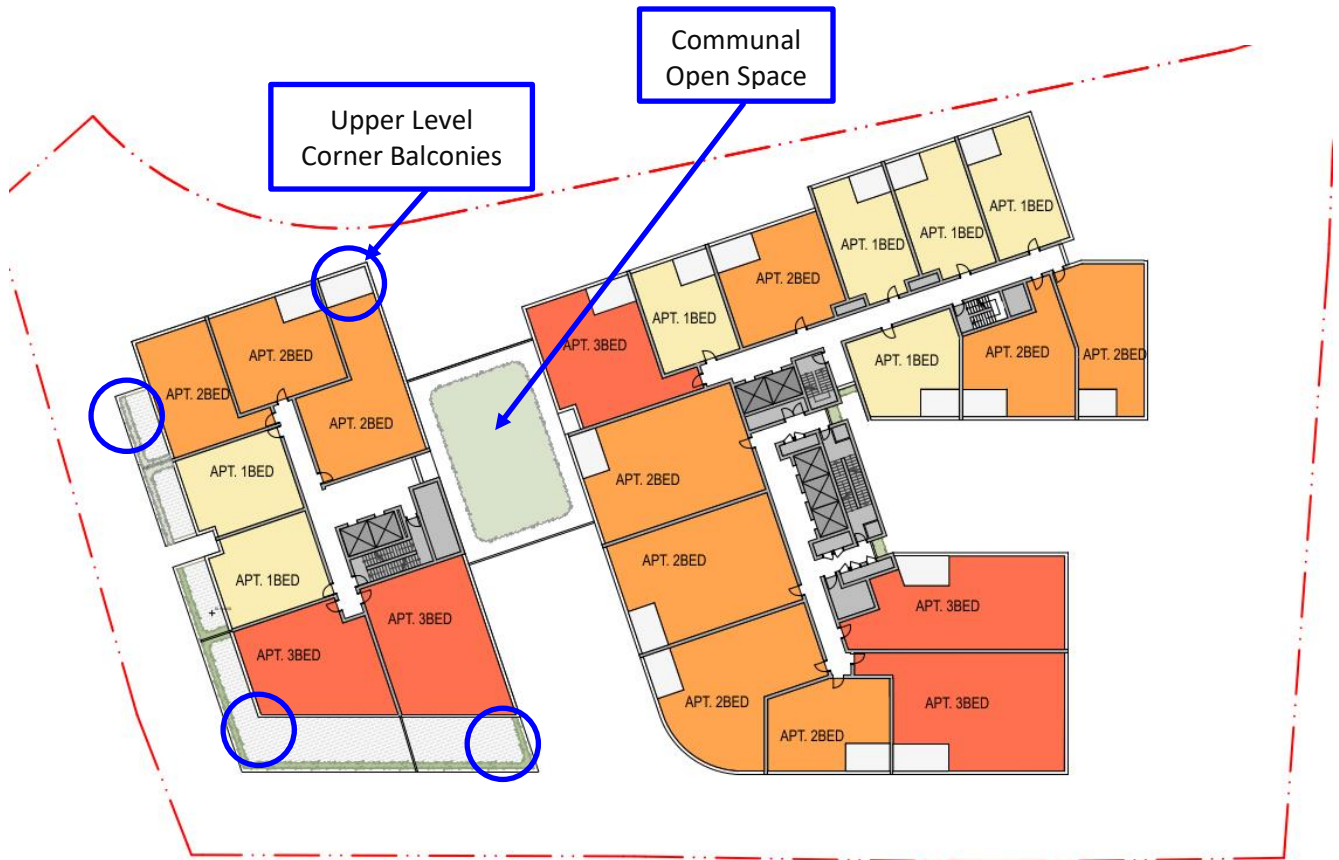

Figure 13 Areas of Interest – Level 05

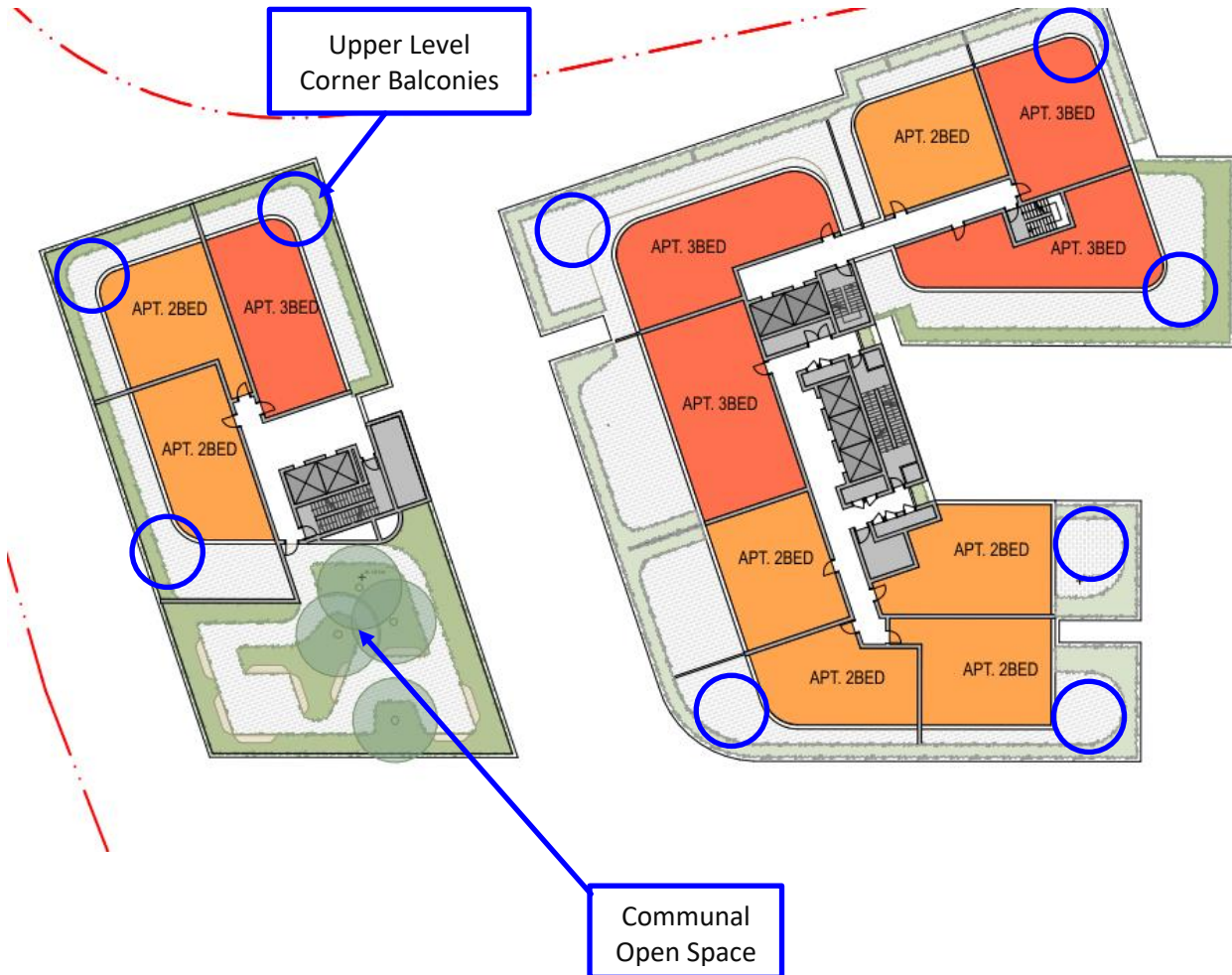

Figure 14 Areas of Interest – Level 08

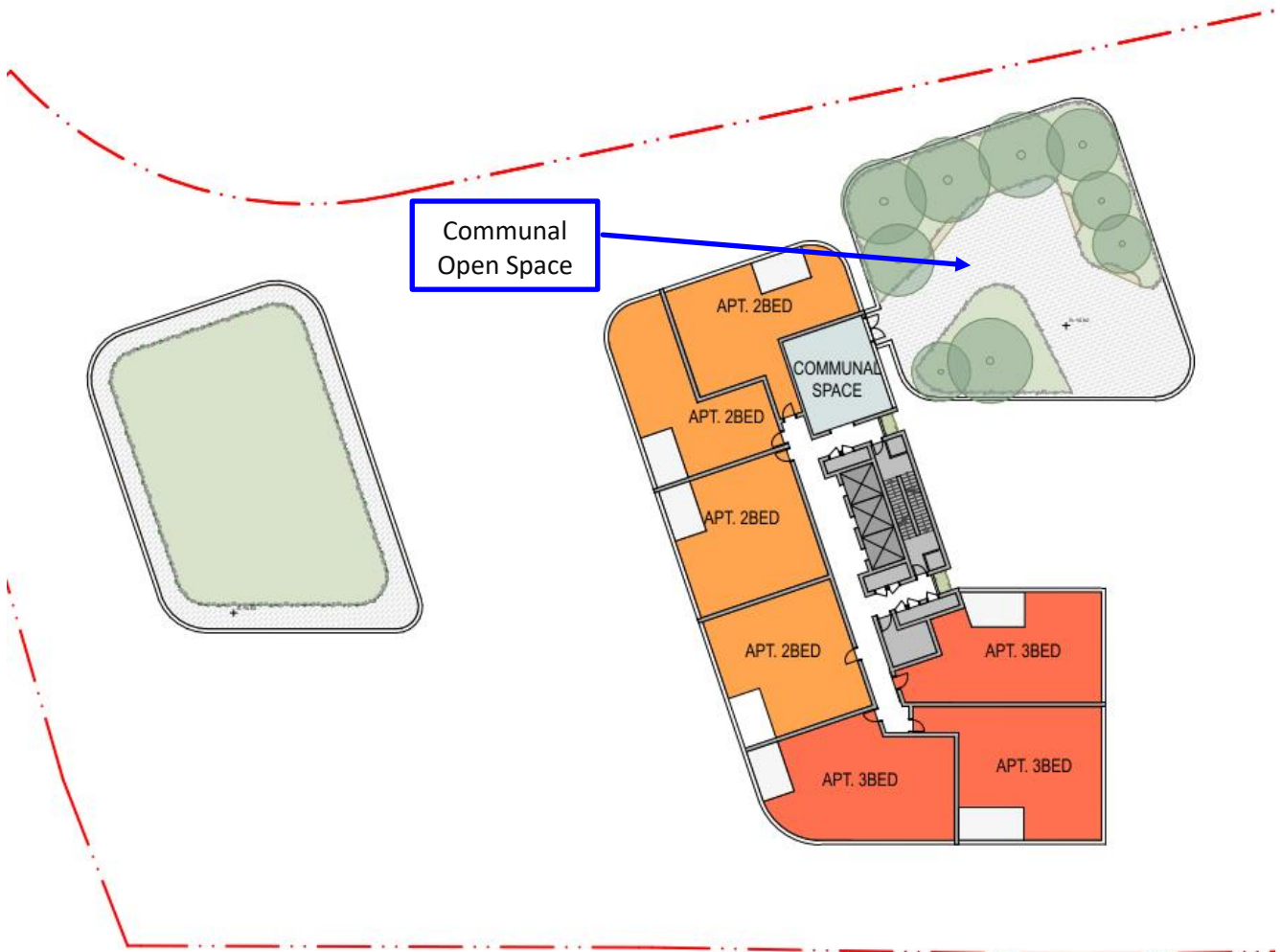
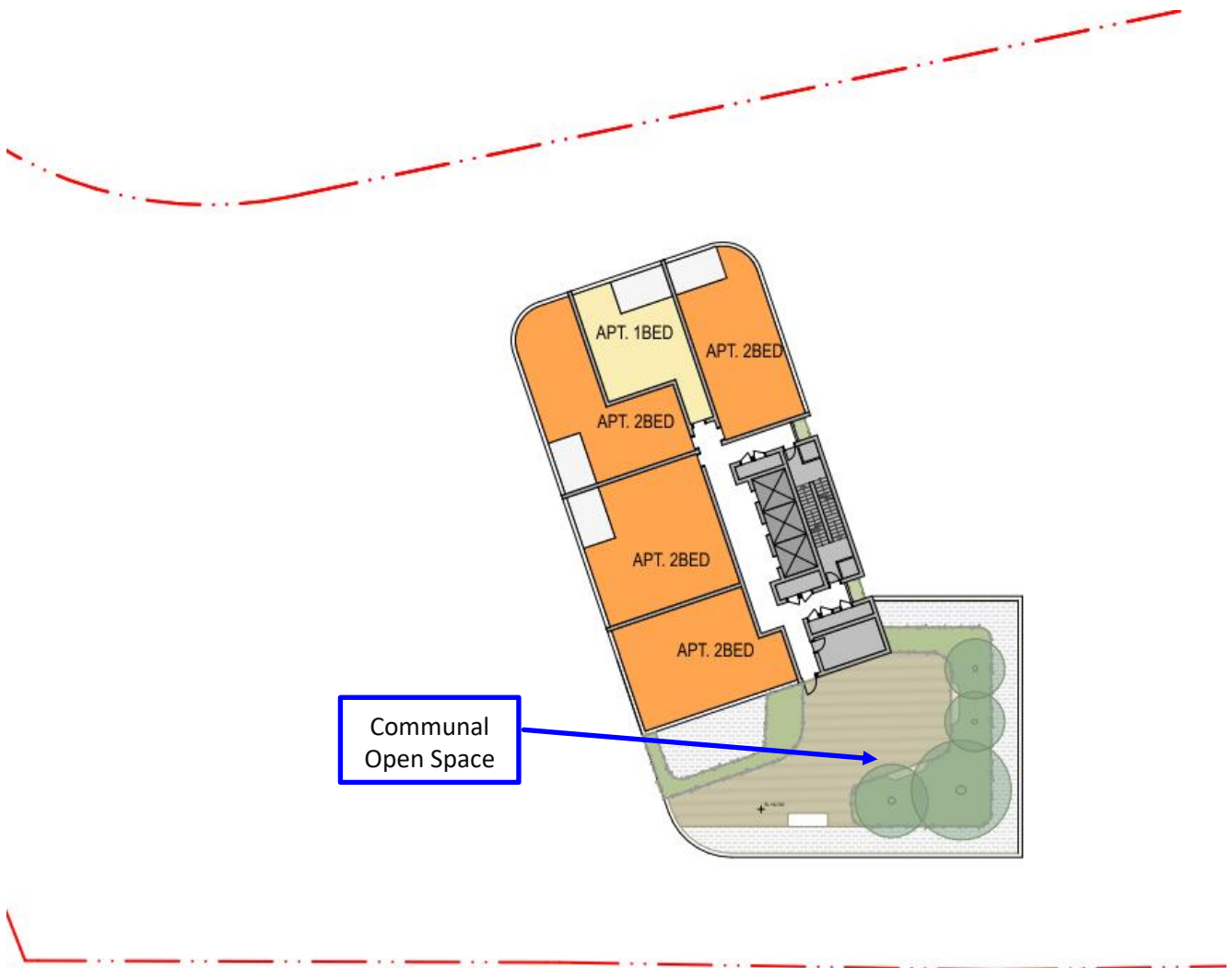

Figure 15 Areas of Interest – Level 19



5.2.1.1 Northeast Winds

Location	Wind Impact
Lower Ground Community Open Space	Potential impact here should be less than 13m/s , affected by: <ul style="list-style-type: none"> • Shielding from existing landscaping. • Shielding from proposed landscaping. • Shielding from the proposed overhang over the communal open space • Shielding from the proposed building.
Northwest Open Space Pathway	Potential impact here should be less than 13m/s , affected by: <ul style="list-style-type: none"> • Shielding from existing landscaping. • Shielding from proposed landscaping. • Shielding from the proposed building. • Potential for corner accelerating winds from the proposed development northwest corner.
Southwest Open Space Pathway	Potential impact here should be less than 13m/s , affected by: <ul style="list-style-type: none"> • Shielding from existing landscaping. • Shielding from proposed landscaping. • Shielding from the proposed building.
Trumper Park Trail	Potential impact here should be less than 13m/s , affected by: <ul style="list-style-type: none"> • Shielding from existing landscaping. • Shielding from proposed landscaping. • Shielding from the proposed building.
Central Courtyard	Potential impact here should be less than 13m/s , affected by: <ul style="list-style-type: none"> • Shielding from existing landscaping. • Shielding from proposed landscaping. • Shielding from the upstream buildings. • Shielding from the proposed buildings. • Potential for channelling winds between the proposed development façades.
Northeast Retail	Potential impact here should be less than 13m/s , affected by: <ul style="list-style-type: none"> • Shielding from existing landscaping. • Shielding from proposed landscaping. • Shielding from the upstream buildings. • Potential for channelling winds along New Mclean Street. • Shielding from the overhang from the upper levels.
Northwest Retail	Potential impact here should be less than 13m/s , affected by: <ul style="list-style-type: none"> • Shielding from existing landscaping. • Shielding from proposed landscaping. • Shielding from the upstream buildings. • Potential for channelling winds along New Mclean Street. • Shielding from the overhang from the upper levels.

Location	Wind Impact
Central Courtyard Retail	Potential impact here could be less than 13m/s , affected by: <ul style="list-style-type: none"> • Shielding from existing landscaping. • Shielding from proposed landscaping. • Shielding from the upstream buildings. • Shielding from the proposed buildings. • Potential for channelling winds between the proposed development façades. • Shielding from the overhang from the upper levels.
Southwest Retail	Potential impact here could be less than 13m/s , affected by: <ul style="list-style-type: none"> • Shielding from existing landscaping. • Shielding from proposed landscaping. • Shielding from the upstream buildings. • Shielding from the proposed buildings. • Potential for channelling winds between the proposed development façades.
Northeast Seating Area	Potential impact here could be close to or exceeding 10 m/s , affected by: <ul style="list-style-type: none"> • Shielding from existing landscaping. • Shielding from proposed landscaping. • Shielding from the upstream buildings. • Potential for channelling winds along New Mclean Street.
Northwest Seating Area	Potential impact here could be close to or exceeding 10 m/s , affected by: <ul style="list-style-type: none"> • Shielding from existing landscaping. • Shielding from proposed landscaping. • Shielding from the upstream buildings. • Potential for channelling winds along New Mclean Street.
Central Courtyard Seating Area	Potential impact here could be close to or exceeding 10 m/s , affected by: <ul style="list-style-type: none"> • Shielding from existing landscaping. • Shielding from proposed landscaping. • Shielding from the upstream buildings. • Shielding from the proposed buildings. • Potential for channelling winds between the proposed development façades.
Southwest Seating Area	Potential impact here could be close to or exceeding 10 m/s , affected by: <ul style="list-style-type: none"> • Shielding from existing landscaping. • Shielding from proposed landscaping. • Shielding from the upstream buildings. • Shielding from the proposed buildings. • Potential for channelling winds between the proposed development façades.
Central Lobby	Potential impact here could be less than 13m/s , affected by: <ul style="list-style-type: none"> • Shielding from existing landscaping. • Shielding from proposed landscaping. • Shielding from the upstream buildings. • Shielding from the proposed buildings. • Potential for channelling winds between the proposed development façades.

Location	Wind Impact
New Mclean Street Pathway	Potential impact here should be less than 16m/s , affected by: <ul style="list-style-type: none"> • Shielding from existing landscaping. • Shielding from proposed landscaping. • Shielding from the upstream buildings. • Potential for channelling winds along New Mclean Street.
Level 1 Communal Open Space	Potential impact here could be less than 10m/s affected by: <ul style="list-style-type: none"> • Shielding from proposed landscaping. • Shielding from the upstream buildings. • Potential for downwashed winds from the building’s eastern façade • The set back design of the communal open space will reduce wind impacting this area.
Level 3 Communal Open Space	Potential impact here could be close to or exceeding 10 m/s affected by: <ul style="list-style-type: none"> • Shielding from proposed landscaping. • Shielding from the upstream buildings. • Potential for downwashed winds from the building’s eastern façade • Potential for corner accelerating winds around the building’s facades.
Level 4 Communal Open Space	Potential impact here could be close to or exceeding 10m/s affected by: <ul style="list-style-type: none"> • Shielding from proposed landscaping. • Shielding from the upstream buildings. • Potential for corner accelerating winds around the building’s facades. • Potential for channelling winds between the proposed development façades.
Level 5 Communal Open Space	Potential impact here could be close to or exceeding 10m/s affected by: <ul style="list-style-type: none"> • Shielding from proposed landscaping. • Shielding from the upstream buildings. • Potential for corner accelerating winds around the building’s facades. • Potential for channelling winds between the proposed development façades. • Reduced upper-level shielding.
Level 8 Communal Open Space	Potential impact here could be close to or exceeding 10m/s affected by: <ul style="list-style-type: none"> • Shielding from proposed landscaping. • Shielding from the upstream buildings. • Potential for corner accelerating winds around the building’s facades. • Potential for channelling winds between the proposed development façades. • Reduced upper-level shielding.
Level 19 Communal Open Space	Potential impact here could be close to or exceeding 10m/s affected by: <ul style="list-style-type: none"> • Shielding from proposed landscaping. • Shielding from the upstream buildings. • Potential for corner accelerating winds around the building’s facades. • Reduced upper-level shielding.

Location	Wind Impact
Private Corner Balconies	Potential impact here could be close to or exceeding 13 m/s , affected by: <ul style="list-style-type: none"> • Reduced upper-level shielding. • Increased wind speeds. • Potential for corner accelerating winds from the proposed development facades.

5.2.1.2 South and Southeast Winds

Location	Wind Impact
Lower Ground Community Open Space	Potential impact here should be less than 13m/s , affected by: <ul style="list-style-type: none"> • Shielding from existing landscaping. • Shielding from proposed landscaping. • The set back design of the communal open space will reduce the impacts of the winds.
Northwest Open Space Pathway	Potential impact here should be less than 13m/s , affected by: <ul style="list-style-type: none"> • Shielding from existing landscaping. • Shielding from proposed landscaping. • Shielding from the proposed building.
Southwest Open Space Pathway	Potential impact here should be less than 13m/s , affected by: <ul style="list-style-type: none"> • Shielding from existing landscaping. • Shielding from proposed landscaping. • Shielding from the proposed building. • Potential for downwashed winds off the building's south facades.
Trumper Park Trail	Potential impact here should be less than 13m/s , affected by: <ul style="list-style-type: none"> • Shielding from existing landscaping. • Shielding from proposed landscaping. • Shielding from the proposed building. • Potential for downwashed winds off the building's south facades.
Central Courtyard	Potential impact here should be less than 13m/s , affected by: <ul style="list-style-type: none"> • Shielding from existing landscaping. • Shielding from proposed landscaping. • Shielding from the proposed buildings. • Potential for channelling winds between the proposed development façades.
Northeast Retail	Potential impact here should be less than 13m/s , affected by: <ul style="list-style-type: none"> • Shielding from existing landscaping. • Shielding from proposed landscaping. • Shielding from the proposed buildings.
Northwest Retail	Potential impact here should be less than 13m/s , affected by: <ul style="list-style-type: none"> • Shielding from existing landscaping. • Shielding from proposed landscaping. • Shielding from the proposed buildings.

Location	Wind Impact
Central Courtyard Retail	Potential impact here could be less than 13m/s , affected by: <ul style="list-style-type: none"> • Shielding from existing landscaping. • Shielding from proposed landscaping. • Shielding from the proposed buildings. • Potential for channelling winds between the proposed development façades. • Shielding from the overhang from the upper levels.
Southwest Retail	Potential impact here could be less than 13m/s , affected by: <ul style="list-style-type: none"> • Shielding from existing landscaping. • Shielding from proposed landscaping. • Shielding from the proposed buildings. • Potential for downwashed winds off the building’s south facades.
Northeast Seating Area	Potential impact here could be less than 10m/s , affected by: <ul style="list-style-type: none"> • Shielding from existing landscaping. • Shielding from proposed landscaping. • Shielding from the proposed buildings. • Potential for channelling winds between the proposed development façades.
Northwest Seating Area	Potential impact here could be less than 10m/s , affected by: <ul style="list-style-type: none"> • Shielding from existing landscaping. • Shielding from proposed landscaping. • Shielding from the proposed buildings. • Potential for channelling winds between the proposed development façades.
Central Courtyard Seating Area	Potential impact here could be close to or exceeding 10 m/s , affected by: <ul style="list-style-type: none"> • Shielding from existing landscaping. • Shielding from proposed landscaping. • Shielding from the proposed buildings. • Potential for channelling winds between the proposed development façades.
Southwest Seating Area	Potential impact here could be close to or exceeding 10 m/s , affected by: <ul style="list-style-type: none"> • Shielding from existing landscaping. • Shielding from proposed landscaping. • Shielding from the proposed buildings. • Potential for downwashed winds off the building’s south facades.
Central Lobby	Potential impact here could be less than 13m/s , affected by: <ul style="list-style-type: none"> • Shielding from existing landscaping. • Shielding from proposed landscaping. • Shielding from the proposed buildings. • Potential for channelling winds between the proposed development façades.

Location	Wind Impact
New Mclean Street Pathway	Potential impact here should be less than 16m/s , affected by: <ul style="list-style-type: none"> • Shielding from existing landscaping. • Shielding from proposed landscaping. • Shielding from the upstream buildings.
Level 1 Communal Open Space	Potential impact here could be less than 10m/s affected by: <ul style="list-style-type: none"> • Shielding from proposed landscaping. • Shielding from the proposed buildings. • The set back design of the communal open space will reduce wind impacting this area.
Level 3 Communal Open Space	Potential impact here could be close to or exceeding 10 m/s affected by: <ul style="list-style-type: none"> • Shielding from proposed landscaping. • Shielding from the proposed buildings. • Potential for corner accelerating winds around the building's facades.
Level 4 Communal Open Space	Potential impact here could be close to or exceeding 10m/s affected by: <ul style="list-style-type: none"> • Shielding from proposed landscaping. • Shielding from the proposed buildings. • Potential for corner accelerating winds around the building's facades. • Potential for channelling winds between the proposed development façades.
Level 5 Communal Open Space	Potential impact here could be close to or exceeding 10m/s affected by: <ul style="list-style-type: none"> • Shielding from proposed landscaping. • Shielding from the upstream buildings. • Potential for corner accelerating winds around the building's facades. • Reduced upper-level shielding.
Level 8 Communal Open Space	Potential impact here could be close to or exceeding 10m/s affected by: <ul style="list-style-type: none"> • Shielding from proposed landscaping. • Shielding from the upstream buildings. • Potential for corner accelerating winds around the building's facades. • Reduced upper-level shielding.
Level 19 Communal Open Space	Potential impact here could be close to or exceeding 10m/s affected by: <ul style="list-style-type: none"> • Shielding from proposed landscaping. • Shielding from the upstream buildings. • Potential for corner accelerating winds around the building's facades. • Reduced upper-level shielding.

Location	Wind Impact
Private Corner Balconies	Potential impact here could be close to or exceeding 13 m/s , affected by: <ul style="list-style-type: none"> • Reduced upper-level shielding. • Increased wind speeds. • Potential for corner accelerating winds from the proposed development facades.

5.2.1.3 Westerly Winds

Location	Wind Impact
Lower Ground Community Open Space	Potential impact here should be less than 13m/s , affected by: <ul style="list-style-type: none"> • Shielding from existing landscaping. • Shielding from proposed landscaping. • Shielding from the proposed overhang over the communal open space • Shielding from the proposed building.
Northwest Open Space Pathway	Potential impact here should be less than 13m/s , affected by: <ul style="list-style-type: none"> • Shielding from existing landscaping. • Shielding from proposed landscaping. • Shielding from the proposed building. • Potential for side streaming winds from the proposed development west façade.
Southwest Open Space Pathway	Potential impact here should be less than 13m/s , affected by: <ul style="list-style-type: none"> • Shielding from existing landscaping. • Shielding from proposed landscaping. • Shielding from the proposed building.
Trumper Park Trail	Potential impact here should be less than 13m/s , affected by: <ul style="list-style-type: none"> • Shielding from existing landscaping. • Shielding from proposed landscaping. • Shielding from the proposed building.
Central Courtyard	Potential impact here should be less than 13m/s , affected by: <ul style="list-style-type: none"> • Shielding from existing landscaping. • Shielding from proposed landscaping. • Shielding from the proposed buildings.
Northeast Retail	Potential impact here should be less than 13m/s , affected by: <ul style="list-style-type: none"> • Shielding from existing landscaping. • Shielding from proposed landscaping. • Shielding from the upstream buildings. • Potential for channelling winds along New Mclean Street.
Northwest Retail	Potential impact here should be less than 13m/s , affected by: <ul style="list-style-type: none"> • Shielding from existing landscaping. • Shielding from proposed landscaping. • Shielding from the upstream buildings. • Potential for channelling winds along New Mclean Street.

Location	Wind Impact
Central Courtyard Retail	Potential impact here could be less than 13m/s , affected by: <ul style="list-style-type: none"> • Shielding from existing landscaping. • Shielding from proposed landscaping. • Shielding from the proposed buildings. • Potential for channelling winds between the proposed development façades. • Shielding from the overhang from the upper levels.
Southwest Retail	Potential impact here could be less than 13m/s , affected by: <ul style="list-style-type: none"> • Shielding from existing landscaping. • Shielding from proposed landscaping. • Shielding from the proposed buildings. • Potential for side streaming winds along the southern façade.
Northeast Seating Area	Potential impact here could be close to or exceeding 10 m/s , affected by: <ul style="list-style-type: none"> • Shielding from existing landscaping. • Shielding from proposed landscaping. • Shielding from the proposed buildings. • Potential for channelling winds along New Mclean Street.
Northwest Seating Area	Potential impact here could be close to or exceeding 10 m/s , affected by: <ul style="list-style-type: none"> • Shielding from existing landscaping. • Shielding from proposed landscaping. • Shielding from the proposed buildings. • Potential for channelling winds along New Mclean Street.
Central Courtyard Seating Area	Potential impact here could be less than 10m/s , affected by: <ul style="list-style-type: none"> • Shielding from existing landscaping. • Shielding from proposed landscaping. • Shielding from the proposed buildings. • Potential for channelling winds between the proposed development façades.
Southwest Seating Area	Potential impact here could be close to or exceeding 10 m/s , affected by: <ul style="list-style-type: none"> • Shielding from existing landscaping. • Shielding from proposed landscaping. • Shielding from the upstream buildings. • Shielding from the proposed buildings. • Potential for side streaming winds along the southern façade.
Central Lobby	Potential impact here could be less than 13m/s , affected by: <ul style="list-style-type: none"> • Shielding from existing landscaping. • Shielding from proposed landscaping. • Shielding from the proposed buildings. • Potential for channelling winds between the proposed development façades.
New Mclean Street Pathway	Potential impact here should be less than 16m/s , affected by: <ul style="list-style-type: none"> • Shielding from existing landscaping. • Shielding from proposed landscaping. • Shielding from the upstream buildings. • Potential for channelling winds along New Mclean Street.

Location	Wind Impact
Level 1 Communal Open Space	Potential impact here could be less than 10m/s affected by: <ul style="list-style-type: none"> • Shielding from proposed landscaping. • Shielding from the proposed buildings. • The set back design of the communal open space will reduce wind impacting this area.
Level 3 Communal Open Space	Potential impact here could be less than 10m/s affected by: <ul style="list-style-type: none"> • Shielding from proposed landscaping. • Shielding from the proposed buildings. • Potential for corner accelerating winds around the building's facades.
Level 4 Communal Open Space	Potential impact here could be less than 10m/s affected by: <ul style="list-style-type: none"> • Shielding from proposed landscaping. • Shielding from the upstream buildings. • Potential for corner accelerating winds around the building's facades.
Level 5 Communal Open Space	Potential impact here could be close to or exceeding 10m/s affected by: <ul style="list-style-type: none"> • Shielding from proposed landscaping. • Shielding from the upstream buildings. • Potential for corner accelerating winds around the building's facades. • Reduced upper-level shielding.
Level 8 Communal Open Space	Potential impact here could be close to or exceeding 10m/s affected by: <ul style="list-style-type: none"> • Shielding from proposed landscaping. • Shielding from the upstream buildings. • Potential for corner accelerating winds around the building's facades. • Reduced upper-level shielding.
Level 19 Communal Open Space	Potential impact here could be close to or exceeding 10m/s affected by: <ul style="list-style-type: none"> • Shielding from proposed landscaping. • Shielding from the upstream buildings. • Potential for corner accelerating winds around the building's facades. • Reduced upper-level shielding.
Private Corner Balconies	Potential impact here could be close to or exceeding 13 m/s , affected by: <ul style="list-style-type: none"> • Reduced upper-level shielding. • Increased wind speeds. • Potential for corner accelerating winds from the proposed development facades.

6 Wind Amelioration Recommendations

On the basis of the expected wind impacts outlined in previous four sections, recommendations for wind break features are made in areas where winds are expected to

- Approach or exceed 10m/s or 13 m/s or 16 m/s depending on the designed use for that area.

These wind mitigation recommendations are summarised in **Table 2**.

Table 2 Recommended Wind Mitigation

Location of Interest	Wind Impact Potential	Windbreak Treatment/Recommendation
Lower Ground Community Open Space	Low Winds should be below 13 m/s for all directions.	No Additional Mitigation Required Retain all proposed landscaping. All landscaping is to be of an evergreen species. Retain the proposed overhang from the levels above.
Northwest Open Space Pathway	Low Winds should be below 13 m/s for all directions.	No Additional Mitigation Required Retain all proposed landscaping. All landscaping is to be of an evergreen species.
Southwest Open Space Pathway	Moderate Winds should be below 13 m/s for all directions.	No Additional Mitigation Required Retain all proposed landscaping. All landscaping is to be of an evergreen species.
Trumper Park Trail	Low Winds should be below 13 m/s for all directions.	No Additional Mitigation Required Retain all proposed landscaping. Additional landscaping could further reduce wind speeds. All landscaping is to be of an evergreen species. Retain the proposed overhang from the levels above.
Central Courtyard	Low Winds should be below 13 m/s for all directions.	No Additional Mitigation Required Retain all proposed landscaping. All landscaping is to be of an evergreen species.

Location of Interest	Wind Impact Potential	Windbreak Treatment/Recommendation
Northeast Retail	<p>Moderate Winds should be below 13 m/s for all directions.</p>	<p>No Additional Mitigation Required Retain all proposed landscaping. Additional landscaping could further reduce wind speeds. All landscaping is to be of an evergreen species. Retain the proposed overhang from the above levels.</p>
Northwest Retail	<p>Moderate Winds should be below 13 m/s for all directions.</p>	<p>No Additional Mitigation Required Retain all proposed landscaping. Additional landscaping could further reduce wind speeds. All landscaping is to be of an evergreen species. Retain the proposed overhang from the above levels.</p>
Central Courtyard Retail	<p>Moderate Winds should be below 13 m/s for all directions.</p>	<p>No Additional Mitigation Required Retain all proposed landscaping. Additional landscaping could further reduce wind speeds. All landscaping is to be of an evergreen species. Retain the proposed overhang from the above levels.</p>
Southwest Retail	<p>Moderate Winds should be below 13 m/s for all directions.</p>	<p>No Additional Mitigation Required Retain all proposed landscaping. Additional landscaping could further reduce wind speeds. All landscaping is to be of an evergreen species. Retain the proposed overhang from the above levels.</p>
Northeast Seating Area	<p>Moderate - High Winds could be above 10 m/s for all prevailing wind directions.</p>	<p>No Additional Mitigation Required Retain all proposed landscaping. Additional landscaping could further reduce wind speeds. All landscaping is to be of an evergreen species. Retain the proposed overhang from the above levels.</p>

Location of Interest	Wind Impact Potential	Windbreak Treatment/Recommendation
Northwest Seating Area	<p>Moderate - High Winds could be above 10 m/s for all prevailing wind directions.</p>	<p>No Additional Mitigation Required Retain all proposed landscaping. Additional landscaping could further reduce wind speeds. All landscaping is to be of an evergreen species. Retain the proposed overhang from the above levels.</p>
Central Courtyard Seating Area	<p>Moderate - High Winds could be above 10 m/s for southerly and north easterly winds</p>	<p>No Additional Mitigation Required Retain all proposed landscaping. Additional landscaping could further reduce wind speeds. All landscaping is to be of an evergreen species. Retain the proposed overhang from the above levels.</p>
Southwest Seating Area	<p>Moderate - High Winds could be above 10 m/s for all prevailing wind directions.</p>	<p>No Additional Mitigation Required Retain all proposed landscaping. Additional landscaping could further reduce wind speeds. All landscaping is to be of an evergreen species. Retain the proposed overhang from the above levels.</p>
Central Lobby	<p>Moderate - High Winds could be above 13 m/s for all prevailing wind directions.</p>	<p>No Additional Mitigation Required Retain all proposed landscaping. Additional landscaping could further reduce wind speeds. All landscaping is to be of an evergreen species. Retain the proposed overhang from the above levels.</p>
New Mclean Street Pathway	<p>Moderate Winds should be below 16 m/s for all directions.</p>	<p>No Additional Mitigation Required Retain all proposed landscaping. Additional landscaping could further reduce wind speeds. All landscaping is to be of an evergreen species.</p>

Location of Interest	Wind Impact Potential	Windbreak Treatment/Recommendation
Level 1 Communal Open Space	<p>Moderate Winds should be below 13 m/s for all directions.</p>	<p>No Additional Mitigation Required Retain all proposed landscaping. Additional landscaping could further reduce wind speeds. All landscaping is to be of an evergreen species.</p>
Level 3 Communal Open Space	<p>Moderate - High Winds could be above 13 m/s for all prevailing wind directions.</p>	<p>Additional Mitigation Required Vertical wind breaks provided by the 1.5m balustrade surrounding the space should be retained. Additional horizontal wind shielding in the form of an awning or other practical wind shielding should be provided above seating areas. Retain all proposed landscaping. Additional landscaping could further reduce wind speeds. All landscaping is to be of an evergreen species.</p>
Level 4 Communal Open Space	<p>Moderate - High Winds could be above 13 m/s for all prevailing wind directions.</p>	<p>Additional Mitigation Required Vertical wind breaks provided by the 1.5m balustrade surrounding the space should be retained. Additional horizontal wind shielding in the form of an awning or other practical wind shielding should be provided above seating areas. Retain all proposed landscaping. Additional landscaping could further reduce wind speeds. All landscaping is to be of an evergreen species.</p>

Location of Interest	Wind Impact Potential	Windbreak Treatment/Recommendation
Level 5 Communal Open Space	<p>Moderate - High Winds could be above 13 m/s for all prevailing wind directions.</p>	<p>Additional Mitigation Required Vertical wind breaks provided by the 1.5m balustrade surrounding the space should be retained. Additional horizontal wind shielding in the form of an awning or other practical wind shielding should be provided above seating areas. Retain all proposed landscaping. Additional landscaping could further reduce wind speeds. All landscaping is to be of an evergreen species.</p>
Level 8 Communal Open Space	<p>Moderate - High Winds could be above 13 m/s for all prevailing wind directions.</p>	<p>Additional Mitigation Required Vertical wind breaks provided by the 1.5m balustrade surrounding the space should be retained. Additional horizontal wind shielding in the form of an awning or other practical wind shielding should be provided above seating areas. Retain all proposed landscaping. Additional landscaping could further reduce wind speeds. All landscaping is to be of an evergreen species.</p>
Level 19 Communal Open Space	<p>Moderate - High Winds could be above 10 m/s for all prevailing wind directions.</p>	<p>Additional Mitigation Required Vertical wind breaks provided by the 1.8m balustrade surrounding the space should be retained. Additional horizontal wind shielding in the form of an awning or other practical wind shielding should be provided above seating areas. Retain all proposed landscaping. Additional landscaping could further reduce wind speeds. All landscaping is to be of an evergreen species.</p>

Location of Interest	Wind Impact Potential	Windbreak Treatment/Recommendation
Private Corner Balconies	Moderate - High Winds could be above 13 m/s for all prevailing wind directions.	Additional Mitigation Required Balconies are recommended to incorporate a nested design with only a single open aspect. It is recommended to include a full height screen on one aspect of the balcony. Alternatively, quantitative assessments such as Computational Fluid Dynamics can be employed during the detailed design phase of the project, to quantify wind speeds at balconies and determine appropriate shielding.

Figure 16 Mitigation Recommendations – Ground Level

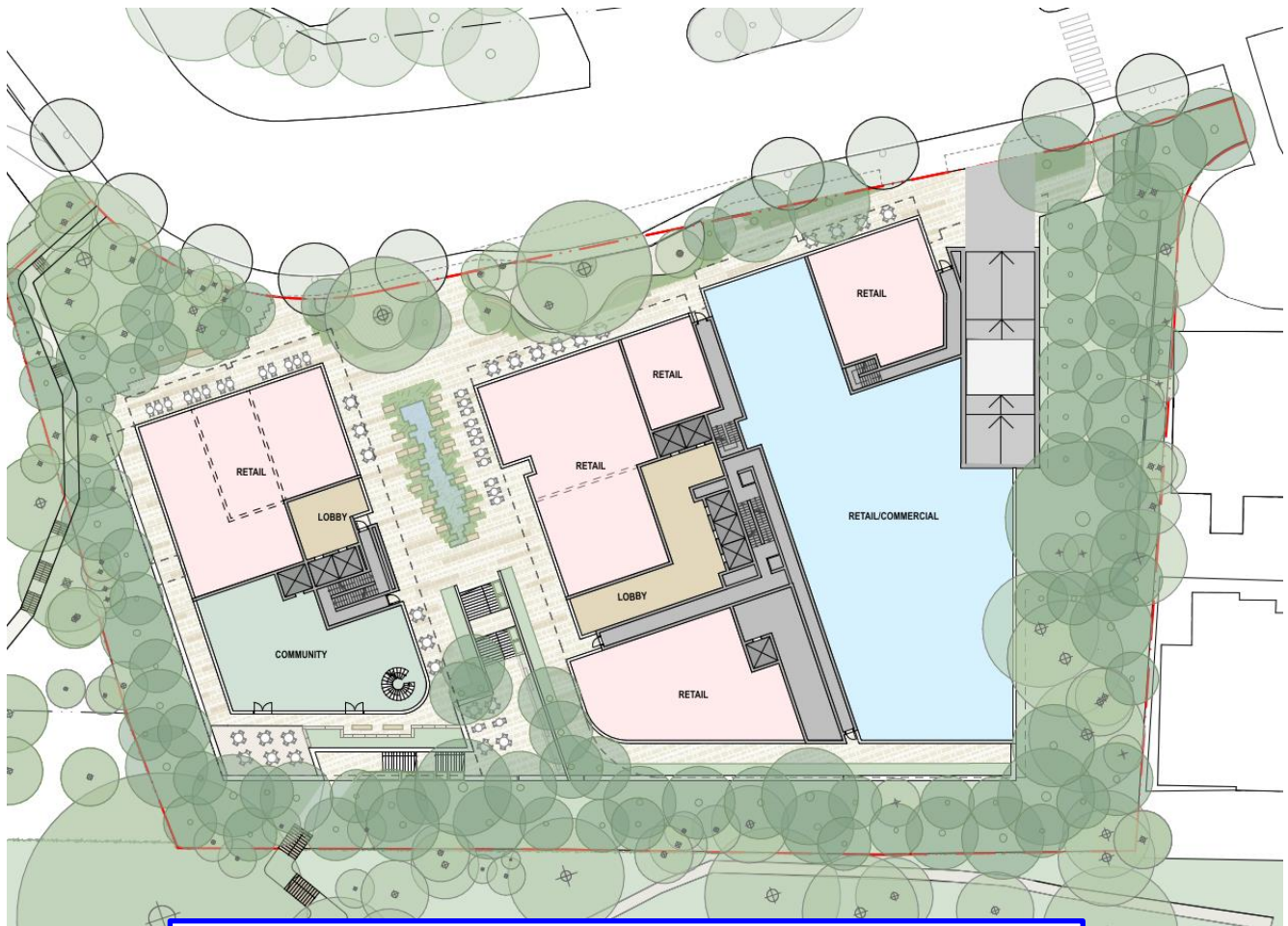

SLR recommends retaining the horizontal windbreak (umbrella, pergola, overhang, canopy) above any seating area.

SLR recommends all proposed landscaping be retained for the ground areas. Majority of landscaping is recommended to be of an evergreen species.

Figure 17 Mitigation Recommendations – Levels 3

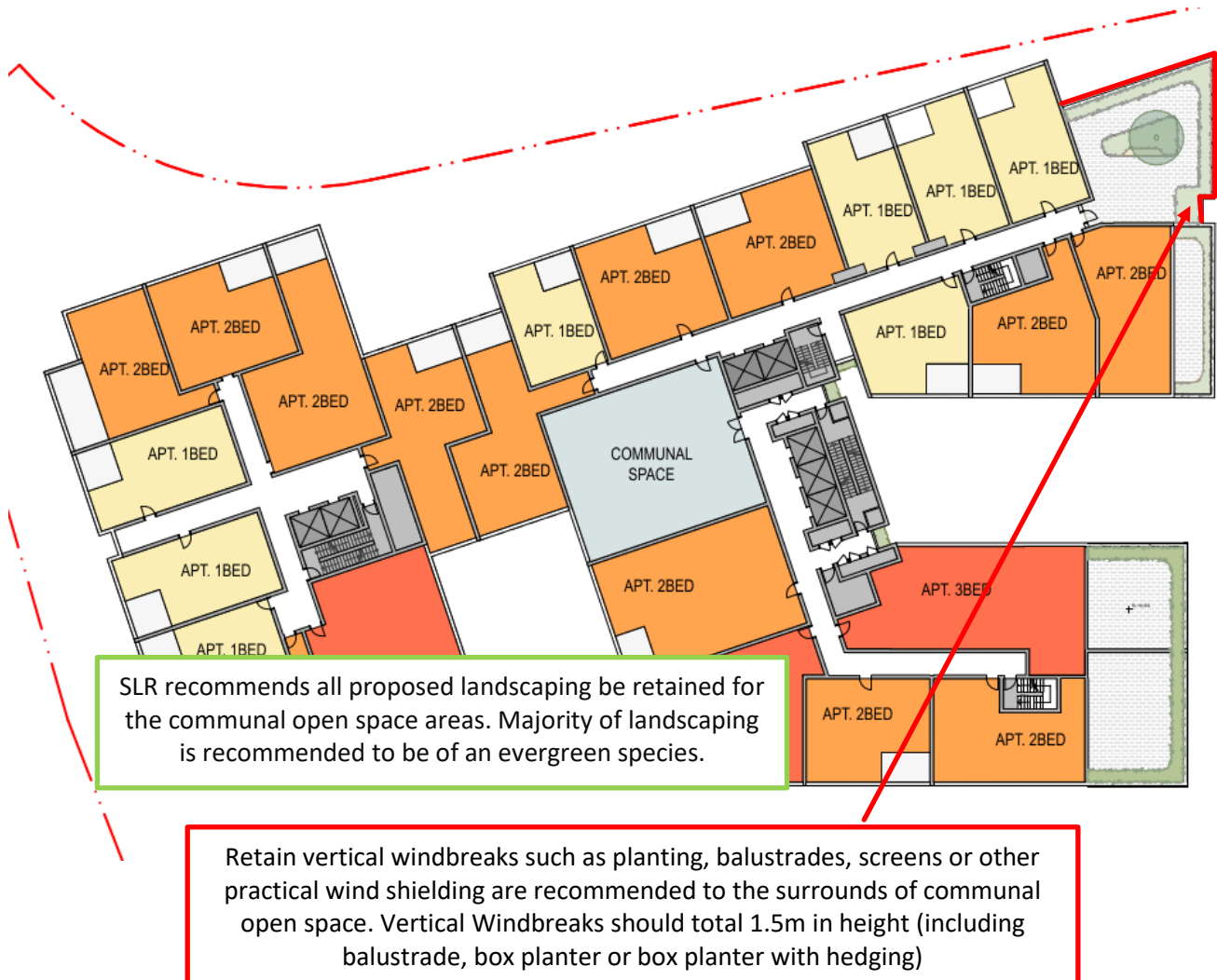

Figure 18 Mitigation Recommendations – Level 04



Retain vertical windbreaks such as planting, balustrades, screens or other practical wind shielding are recommended to the surrounds of communal open space. Vertical Windbreaks should total 1.5m in height (including balustrade, box planter or box planter with hedging)

Balconies are recommended to incorporate a nested design with only a single open aspect. It is recommended to include a full height screen on one aspect of the balcony. Alternatively, quantitative assessments such as Computational Fluid Dynamics can be employed during the detailed design phase of the project, to quantify wind speeds at balconies and determine appropriate shielding.

SLR recommends all proposed landscaping be retained for the communal open space areas. Majority of landscaping is recommended to be of an evergreen species.

Figure 19 Mitigation Recommendations – Level 05

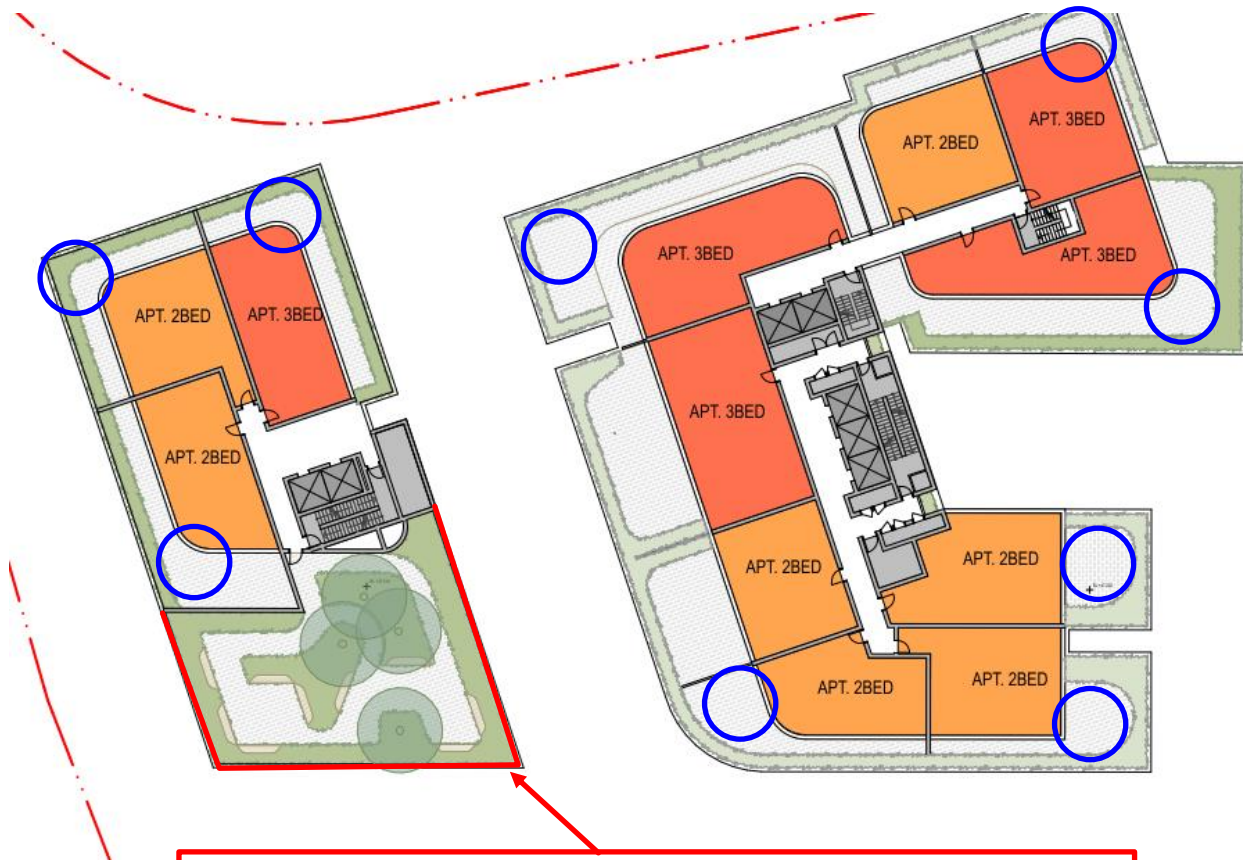

Retain vertical windbreaks such as planting, balustrades, screens or other practical wind shielding are recommended to the surrounds of communal open space. Vertical Windbreaks should total 1.5m in height (including balustrade, box planter or box planter with hedging)

Balconies are recommended to incorporate a nested design with only a single open aspect. It is recommended to include a full height screen on one aspect of the balcony. Alternatively, quantitative assessments such as Computational Fluid Dynamics can be employed during the detailed design phase of the project, to quantify wind speeds at balconies and determine appropriate shielding.

SLR recommends all proposed landscaping be retained for the communal open space areas. Majority of landscaping is recommended to be of an evergreen species.

Figure 20 Mitigation Recommendations – Level 08

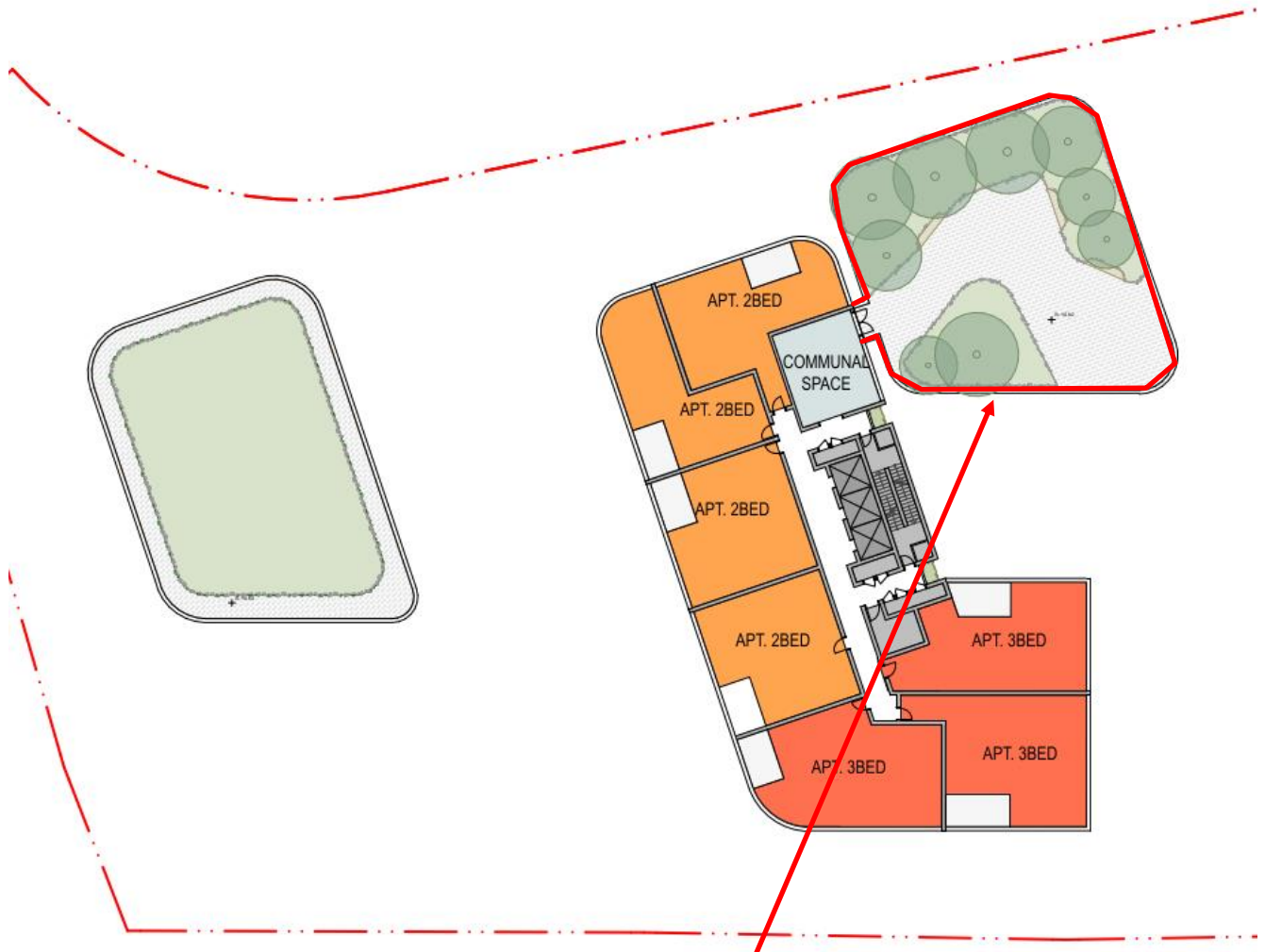

Retain vertical windbreaks such as planting, balustrades, screens or other practical wind shielding are recommended to the surrounds of communal open space. Vertical Windbreaks should total 1.5m in height (including balustrade, box planter or box planter with hedging)

SLR recommends all proposed landscaping be retained for the communal open space areas. Majority of landscaping is recommended to be of an evergreen species.

Figure 21 Mitigation Recommendations – Level 19

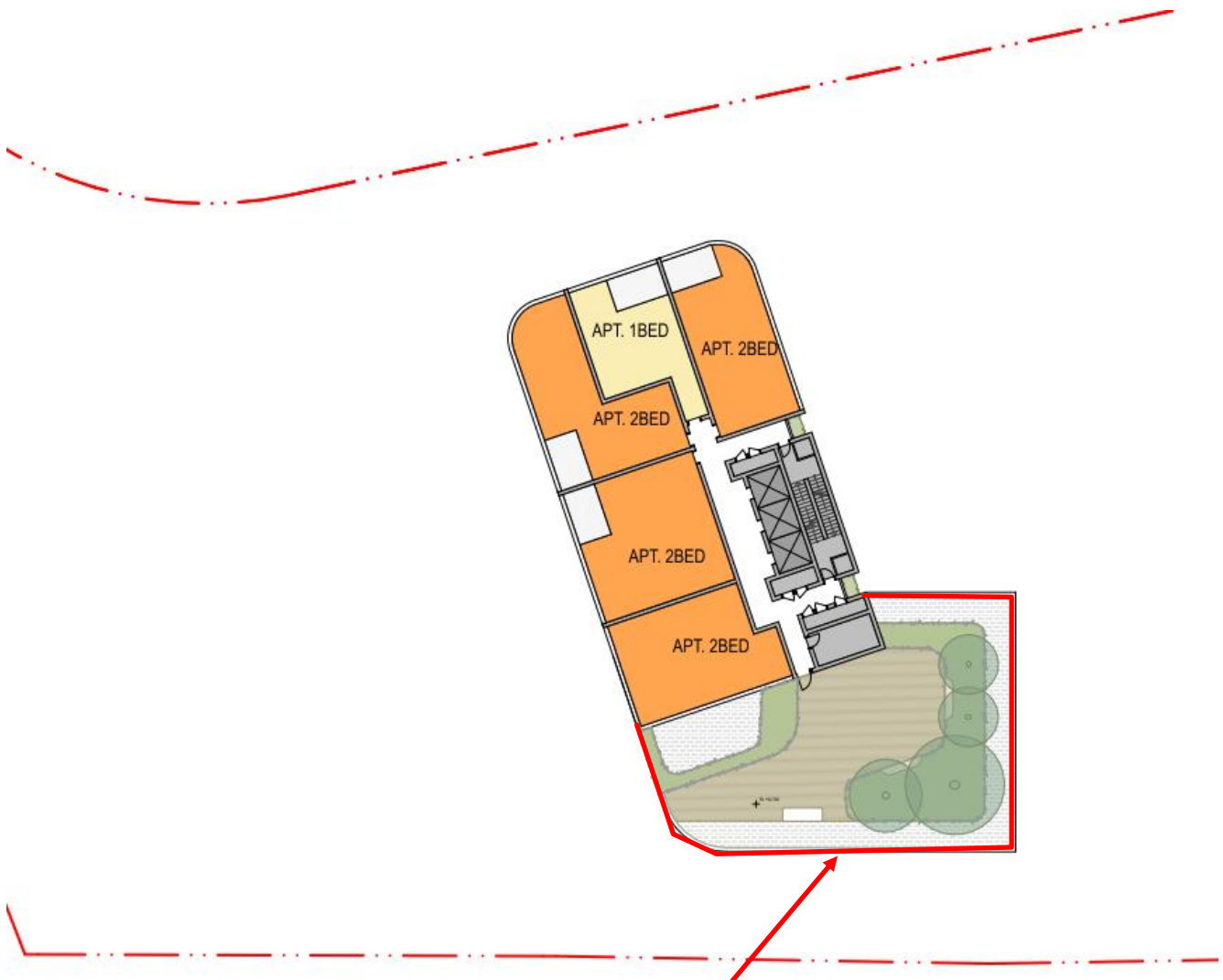

Retain vertical windbreaks such as planting, balustrades, screens or other practical wind shielding are recommended to the surrounds of communal open space. Vertical Windbreaks should total 1.8m in height (including balustrade, box planter or box planter with hedging)

SLR recommends all proposed landscaping be retained for the communal open space areas. Majority of landscaping is recommended to be of an evergreen species.

7 Conclusion

SLR Consulting Pty Ltd (SLR) has been engaged by Mount St 4 Pty Ltd to undertake a qualitative wind assessment of the proposed up to 25-storey at 8-10 New McLean St, Edgecliff, mixed use development. This assessment will form part of the application to Woollahra Municipal Council.

The “near-field” built environment comprises a combination of medium to high rise residential and commercial buildings to the south and west, with a waterfront area to the east, and blocks of low-rise residential houses to the north and northeast.

Prevailing wind directions of interest in Sydney are from northeast, south, southeast and west quadrants. Their seasonal variation is described in **Section 2** of this report.

Existing Wind Environment

Existing street level wind conditions in the vicinity of the site could be close to or greater than 16 m/s “walking comfort” criterion for some prevailing wind directions, resulting from channelling of winds along aligning streets.

Future Wind Environment

In terms of the future wind environment with the proposed development, the following features of the development are noted as being of most significance:

- The winds along the surrounding footpaths should remain at similar levels or improve providing appropriate landscaping is employed as proposed.
- Retention of horizontal wind breaks are recommended over building entries, to protect against potential downwash from the high-level development. These breaks can be in the form of landscaping or construction features. Furthermore, pergolas are recommended above seating areas in the communal open spaces.
- Vertical windbreaks are recommended to the the communal open space areas.
- Retention of all proposed landscaping be retained. Majority of landscaping is recommended to be of an evergreen species.

The above analysis has been made on the basis of our best engineering judgment and on the experience gained from scale model wind tunnel testing or computational fluid dynamics analysis of a range of developments. The conclusions of this SLR report will be quantified using wind tunnel testing.

APPENDIX A

Sydney Wind Roses

Morning Winds

Summer Winds

Spring

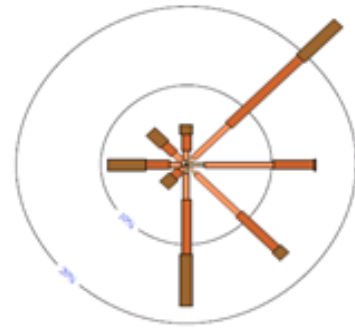
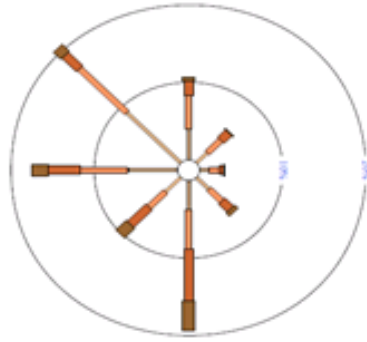

Summer

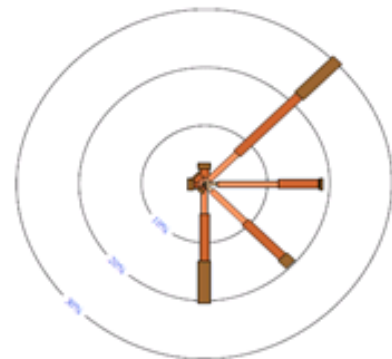
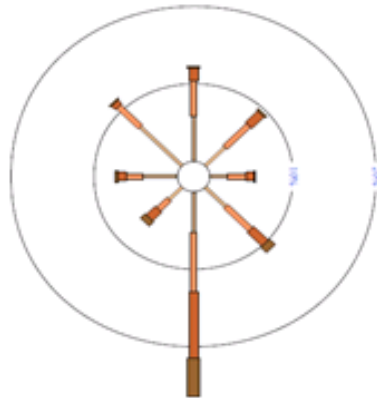

Autumn

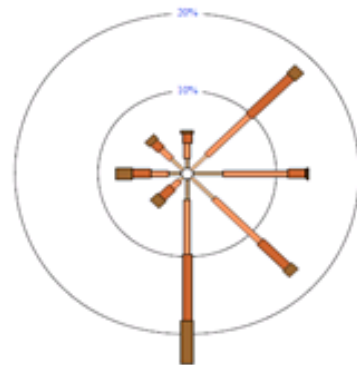
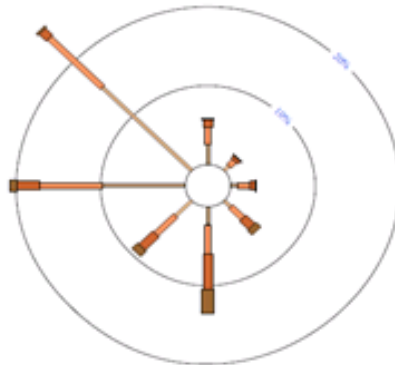

Winter

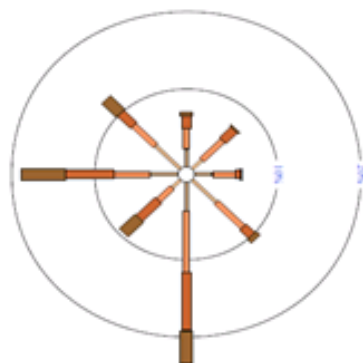
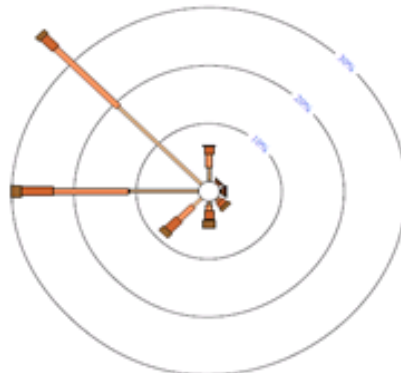

ASIA PACIFIC OFFICES

BRISBANE

Level 2, 15 Astor Terrace
Spring Hill QLD 4000
Australia
T: +61 7 3858 4800
F: +61 7 3858 4801

MACKAY

21 River Street
Mackay QLD 4740
Australia
T: +61 7 3181 3300

SYDNEY

2 Lincoln Street
Lane Cove NSW 2066
Australia
T: +61 2 9427 8100
F: +61 2 9427 8200

AUCKLAND

68 Beach Road
Auckland 1010
New Zealand
T: +64 27 441 7849

CANBERRA

GPO 410
Canberra ACT 2600
Australia
T: +61 2 6287 0800
F: +61 2 9427 8200

MELBOURNE

Suite 2, 2 Domville Avenue
Hawthorn VIC 3122
Australia
T: +61 3 9249 9400
F: +61 3 9249 9499

TOWNSVILLE

Level 1, 514 Sturt Street
Townsville QLD 4810
Australia
T: +61 7 4722 8000
F: +61 7 4722 8001

NELSON

6/A Cambridge Street
Richmond, Nelson 7020
New Zealand
T: +64 274 898 628

DARWIN

5 Foelsche Street
Darwin NT 0800
Australia
T: +61 8 8998 0100
F: +61 2 9427 8200

NEWCASTLE

10 Kings Road
New Lambton NSW 2305
Australia
T: +61 2 4037 3200
F: +61 2 4037 3201

GOLD COAST

Ground Floor, 194 Varsity Parade
Varsity Lakes QLD 4227
Australia
M: +61 438 763 516

PERTH

Ground Floor, 503 Murray Street
Perth WA 6000
Australia
T: +61 8 9422 5900
F: +61 8 9422 5901