

Neighbourhood Centres Development Control Plan

Approved 27 January 2009
Commencing 4 February 2009



Plumer Road, Rose Bay

Table of Contents

Preliminary

PART 1

1.1	Background	3
1.2	About the NC DCP	3
1.3	Land and development to which the NC DCP applies	3
1.4	Applications to which the NC DCP applies	5
1.5	Objectives of the NC DCP	5
1.6	How to use the NC DCP's controls	5
1.6.1	Part 4: Precinct controls	6
1.6.2	Part 5: General controls	7
1.7	Relationship of the NC DCP to other documents	8
1.7.1	The Act and the Regulation	8
1.7.2	State policies and regional plans	8
1.7.3	Woollahra LEP 1995	8
1.7.4	Other Woollahra DCP's, policies and codes	9
1.8	Savings and transitional provisions	10
1.9	Approval and commencement of this plan	10

Making an application

PART 2

2.1	When is an application required?	13
2.2	The assessment process	13
2.3	How are applications determined?	14
2.4	Other approvals that may be necessary	15

Retail Context

PART 3

3.1	Retail hierarchy in Woollahra	19
3.2	Retail trends and neighbourhood centres	19
3.3	Neighbourhood centres performance	20

Precinct controls

PART 4

4.1	Hopetoun Avenue, Vaucluse	24
4.2	South Head Roundabout, Vaucluse	28
4.3	Vaucluse Shopping Village	31
4.4	Rose Bay North	35
4.5	Rose Bay South	39
4.6	Plumer Road, Rose Bay	43
4.7	O'Sullivan Road, Rose Bay West	47
4.8	Bellevue Hill	50
4.9	Streatfield Road, Bellevue Hill	54

4.10	Manning Road, Woollahra	58
4.11	Mitchell Street, Darling Point	62

General controls

PART 5

5.1	Uses	70
5.2	Street character	71
5.3	Built form	74
5.4	Building articulation	78
5.5	Heritage and Contributory buildings	80
5.6	Energy efficiency	82
5.7	Stormwater management	88
5.8	Acoustic and visual privacy	90
5.9	Car parking, vehicular access and servicing	93
5.10	Site facilities	96
5.11	Advertising, signage and illumination	98
5.12	Access and mobility	100
5.13	Footpath dining	101
5.14	Landscaped open space	102
5.15	Telecommunications and radiocommunications	103

Definitions

PART 6

	Definitions	107
--	-------------	------------

Acknowledgments

This development control plan was prepared by Woollahra Council, under the direction of the Strategic Planning Working Party.

WOOLLAHRA COUNCIL STRATEGIC PLANNING WORKING PARTY

Councillor Isabelle Shapiro, Chair
Councillor Geoff Rundle
Councillor John Comino
Councillor Chris Dawson
Councillor Tanya Excell
Councillor Wilhemina Gardner
Councillor Keri Huxley
Councillor David Shoebridge
Councillor Anthony Boskovitz

WOOLLAHRA COUNCIL

Susan Young Urban Design Planner
Margaret Zulaikha, Team Leader Urban Design
Allan Coker, Director Planning and Development
Christopher Bluett, Manager Strategic Planning
Susan Phillips, Team Administrator

CONSULTANTS

Peter Leyshon of Leyshon Consulting provided advice on the retail and land use component of the Neighbourhood Centres Strategy.

P A R T

1

Preliminary

PART 1

1.1 BACKGROUND

The neighbourhood shopping centres across the municipality generally provide essential retail and commercial services for their local communities. However they vary considerably in size, built form, uses and economic vitality.

Council has resolved to support the long term retail health and viability of each centre and initiated the Neighbourhood Centre Strategy. The strategy is underpinned by the principles for economic and social sustainability: where neighbourhood centres would provide a good mix of local services, a greater choice in housing close to shops, safe and active streets and places for community life, more walkable precincts and access to public transport.

The Neighbourhood Centres Development Control Plan (NC DCP) provides urban design guidelines and development controls to support desirable uses, structure, form and character for each centre. These guidelines include opportunities for 'mixed use' retail/residential development, improvements to public places and streets, and requirements for buildings with reduced reliance on non-renewable resources.

1.2 ABOUT THE DCP

This development control plan is known as "Neighbourhood Centres Development Control Plan". The NC DCP uses a "performance approach" to direct the design of building development. This allows flexibility for innovation and expression in building design while at the same time ensuring developments meet important neighbourhood character and site planning objectives.

Applicants and designers will need to read all sections of the NC DCP in order to make sure that they have met the NC DCP's performance requirements. The NC DCP's development controls are contained in the following three sections:

- **Part 3: Retail context**
- **Part 4: Precinct controls** - contains desired future character objectives and performance criteria for individual centres. (Figure 1.3 on page 4 will show you which precinct your development lies within); and
- **Part 5: General controls** - contains objectives and performance criteria that apply to all areas covered by the DCP.

1.3 LAND AND DEVELOPMENT TO WHICH THE DCP APPLIES

This NC DCP applies to the Neighbourhood Centres as defined by the Precinct maps in Part 4: Precinct controls. For local neighbourhood shopping centres that are located within areas covered by a specific Heritage Conservation Area DCP please refer to the relevant DCP for development guidelines and controls:

Paddington Heritage Conservation Area DCP 1999
 Woollahra Heritage Conservation Area DCP 2003
 Watsons Bay Heritage Conservation Area DCP 2003

FIGURE 1.3:
WHERE THE NC DCP APPLIES

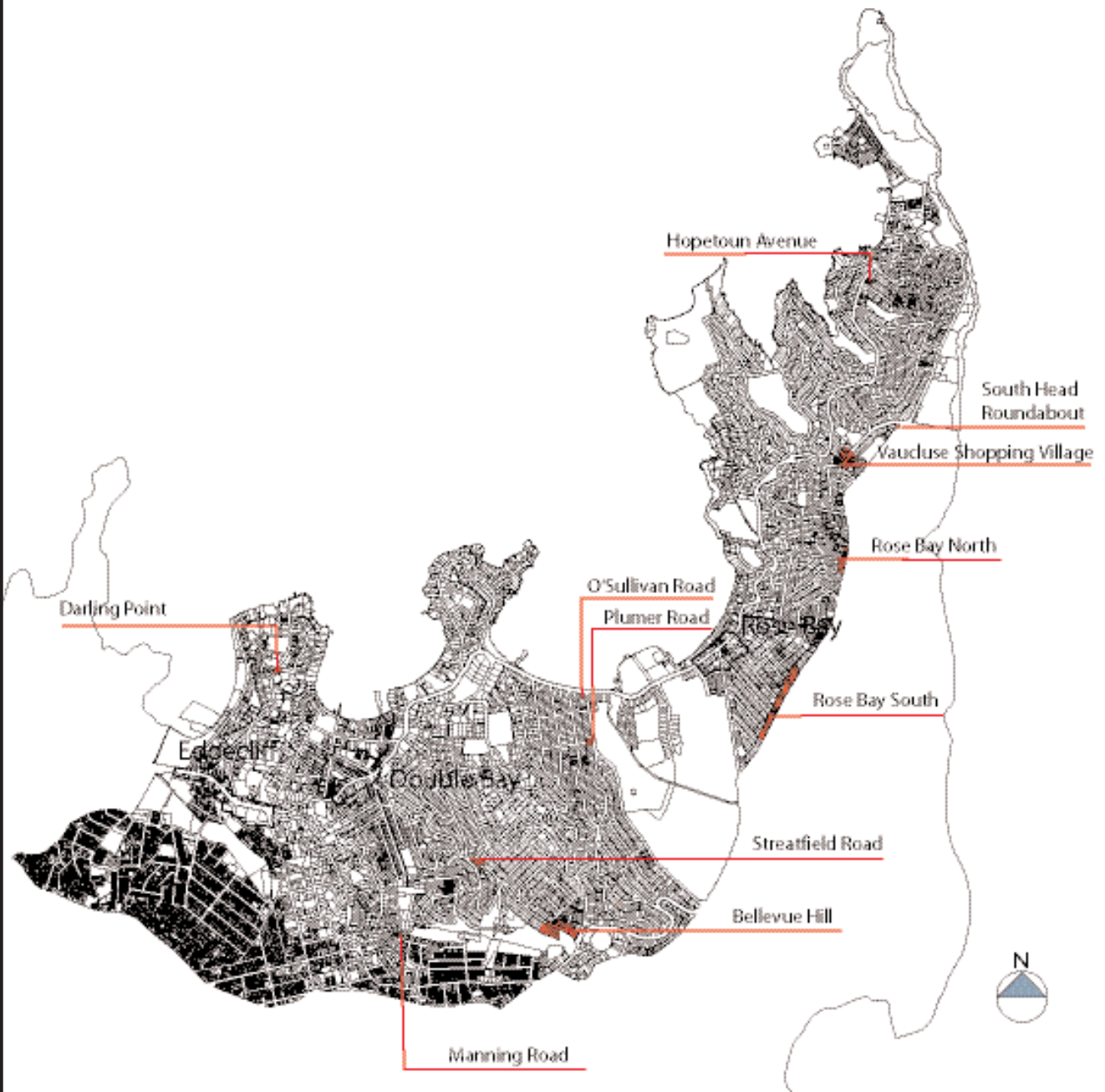

**1.4
APPLICATIONS TO
WHICH THE NC DCP
APPLIES**

The NC DCP applies to development applications, applications to modify development consents under section 96 of the *Environmental Planning and Assessment Act 1979* (the Act) and applications for review of determination under section 82A of the Act which are made on or after the commencement date of this NC DCP.

**1.5
OBJECTIVES OF THE
DCP**

The objectives of the NC DCP are:

- (a) to support the long term retail health of local neighbourhood shopping centres;
- (b) to facilitate development in a way that reflects desired future character objectives for each precinct;
- (c) to enhance the mix of local services;
- (d) to preserve the small shop character of each centre;
- (e) to increase the number of people living in mixed use developments within neighbourhood centres;
- (f) to provide a range and mix of dwellings that are compatible with retail and or commercial uses;
- (g) to ensure a high standard of architectural and landscape design in any new development that is compatible with existing built fabric;
- (h) to minimise the negative impacts of development on the amenity of adjoining and neighbouring properties;
- (i) to improve the safety and amenity of the pedestrian environment;
- (j) to promote development that achieves the principles of ecologically sustainable development;
- (k) to provide a balance between flexibility and certainty in the development assessment process; and
- (l) to provide community facilities where appropriate as part of redevelopment.

**1.6
HOW TO USE THE
DCP'S CONTROLS**

Applicants should read this section in order to understand how to use the NC DCP's development controls.

The NC DCP's controls are contained in three sections:

- Part 3: Retail context;
- Part 4: Precinct controls; and
- Part 5: General controls.

Applicants will need to comply with the requirements of all three sections in order to ensure their development meets the NC DCP's requirements. In all sections, references to relevant provisions within the Woollahra LEP 1995 (as amended) are also included to assist applicants. While the NC DCP contains most of the detailed design controls for development, the LEP also contains important objectives and controls that will need to be met.

Some objectives and performance criteria may not be relevant to all sites. Where applicants believe that provisions are not relevant, the statement of environmental effects accompanying the development application must provide a justification for not addressing the provisions.

Note: Unless otherwise indicated, where there is any disparity between the objectives and performance criteria in Parts 4 and 5, the objectives and performance criteria in Part 4: Precinct controls take precedence.

1.6.1 Each section in Part 4 represents an individual "character precinct". The NC DCP contains
PART 4: precinct controls for eleven individual precincts. Figure 1.3 on page 4 shows the precincts.
PRECINCT CONTROLS Applicants need only refer to the individual precinct that is relevant to their site in this Part.

The controls for each character precinct comprise four elements:

- a precinct map showing the land to which specific objectives and performance criteria apply;
- a brief description of the precinct;
- a set of desired future character objectives for the precinct; and
- performance criteria which apply to the precinct.

The desired future character objectives for each precinct describe the outcomes that are required to be achieved through development within the precinct. In order to gain Council approval, developments need to demonstrate that they have fulfilled the relevant objectives.

The performance criteria describe specific ways in which the desired future character objectives can be met. In particular, the performance criteria for each precinct require developments to preserve or enhance the important character elements for the precinct, where these are relevant to the site.

General controls apply to all sites regardless of the precinct in which they are located. The general controls are divided into fifteen parts. Developments are required to fulfil the relevant requirements of all general controls.

The General controls in Part 5 comprise three elements:

- an explanation of the topic;
- a set of objectives; and
- performance criteria.

Each topic provides background information on why the topic is important and how it is relevant to building design. The explanation will help to determine in what ways the general controls should be applied to development. The objectives for each topic describe the outcomes that proposed development is required to achieve. In order to gain Council approval, developments need to demonstrate that they have fulfilled the relevant objectives for each topic.

The performance criteria represent specific ways in which a development proposal can meet the objectives for the topic. Development proposals are required to address all relevant performance criteria. The intent of the performance criteria must be interpreted in the context of the topic's objectives.

1.6.2
PART 5:
GENERAL CONTROLS

1.7
RELATIONSHIP OF
THIS DCP TO
OTHER
DOCUMENTS

1.7.1
THE ACT AND THE
REGULATION

The NC DCP has been prepared under Division 6 of the *Environmental Planning and Assessment Act 1979* and Part 3 of the *Environmental Planning and Assessment Regulation 2000*.

1.7.2
STATE POLICIES AND
REGIONAL PLANS

State environmental planning policies and regional environmental plans may apply to the land to which the NC DCP applies. Where this occurs, the statutory provisions of those policies and plans prevail over the NC DCP.

1.7.3
WOOLLAHRA LEP 1995

Woollahra Local Environmental Plan 1995 applies to the land to which the NC DCP applies. Woollahra LEP 1995 is a statutory instrument that sets out the land use zones and broad development controls for development within the municipality, including controls for height, floor space ratio (for certain development), special sites and areas, heritage conservation areas and heritage items.

The NC DCP supplements the provisions of Woollahra LEP 1995. The provisions of Woollahra LEP 1995 prevail over the NC DCP.

1.7.4
OTHER WOOLLAHRA DCPS,
POLICIES AND CODES

In the event of any other inconsistency between the NC DCP and other policies and codes, the NC DCP prevails unless otherwise specified in this plan or in other plans, policies and codes.

The following DCP's do not apply on the land subject to the NC DCP, with effect from the commencement date of the DCP:

- Woollahra Residential DCP 1995
- Woollahra Residential DCP 1998
- Woollahra Residential DCP 1999
- Woollahra Residential DCP 2003
- Access DCP (2004)
- Telecommunications and Radiocommunications DCP (2004)

- Woollahra Parking DCP
- Exempt and Complying Development DCP

However the NC DCP adopts:

- the provisions of the Access DCP (2004)
- the provisions of the Telecommunications and Radiocommunications DCP (2004)
- the provisions of the Woollahra Parking DCP
- the provisions of the Exempt and Complying Development DCP

as if those provisions were still applicable to land to which NC DCP applies.

Despite the statements and the repeal of development control plans, policies and codes referred to in clause 1.7.4, the following savings and transitional provisions apply as if clause 1.7.4 did not operate:

Notwithstanding the amendment effected by clause 1.7.4 and despite any other provision of this Plan, the provisions of Woollahra Residential DCP 1995 (RDGP) are adopted as provisions of the Plan and apply (in respect of land to which this Plan applies) to development applications, applications to modify development consents under section 96 of the *Environmental Planning and Assessment Act 1979* and applications for review of determination under section 82A of the *Environmental Planning and Assessment Act 1979* that were made prior to but not determined on the date of commencement of this Plan as if those provisions were still applicable to land to which this Plan applies.

Notwithstanding the amendment effected by clause 1.7.4 and despite any other provision of this Plan, the provisions of Woollahra Residential DCP 1998 are adopted as provisions of this Plan and apply (in respect of land to which this Plan applies) to development applications and applications to modify development consents under section 96 of the *Environmental Planning and Assessment Act 1979* that were made after 6 April 1998 but before the commencement date of Woollahra Residential DCP 1999 (20 September 1999) and which were not determined on the date of commencement of this Plan as if those provisions were still applicable to land to which this Plan applies.

1.8 SAVINGS AND TRANSITIONAL PROVISIONS

Notwithstanding the amendment effected by clause 1.7.4 and despite any other provision of this Plan, the provisions of Woollahra Residential DCP 1999(as amended by amendments 1,2, 3 and 4) are adopted as provisions of this Plan and apply (in respect of land to which this Plan applies) to development applications, applications to modify development consents under section 96 of the *Environmental Planning and Assessment Act 1979* and applications for review of determination under section 82A of the *Environmental Planning and Assessment Act 1979* that were made after 20 September 1999 but before the commencement of RDCP 2003 (27 February 2004) and which were not determined on the date of commencement of this Plan as if those provisions were still applicable to land to which this Plan applies.

Notwithstanding the amendment effected by clause 1.7.4 and despite any other provision of this Plan, the provisions of Woollahra Residential DCP 2003 continues to apply (in respect of land to which the NC DCP applies) are adopted as provisions of this Plan and apply to development applications, applications to modify development consents under section 96 of the *Environmental Planning and Assessment Act 1979* and applications for review of determination under section 82A of the *Environmental Planning and Assessment Act 1979* that were made prior to but not determined on the date of commencement of this Plan as if those provisions were still applicable to land to which this Plan applies.

The development control plans referred to in clause 1.7.4 continue to apply (in respect to land to which the NC DCP applies) to development applications, applications to modify development consents under section 96 of the *Environmental Planning and Assessment Act 1979* and applications for review of determination under section 82A of the *Environmental Planning and Assessment Act 1979* that were made prior to but not determined on the date of commencement of the NC DCP 2006.

1.9
APPROVAL AND
COMMENCEMENT
OF THIS PLAN

The NC DCP was approved by Woollahra Council on 27 January 2009 and commenced on 4 February 2009

PART

2

Making an application

PART 2

Applicants are strongly advised to make an appointment for a formal pre-Development Application (DA) consultation with Council's Assessment Officers before detailed plans for the proposal are drawn up. This will help to identify important issues at an early stage and avoid later problems in the assessment process.

Development applications in respect of land to which the ND DCP applies are generally required for the following activities:*

- a change of use;
- erect a new building or structure, including such things as awnings, out-buildings, swimming pools and retaining walls;
- add to or alter an existing building (including fences and air-conditioning devices);
- demolish a building;
- change the use of an existing building or parcel of land to another use;
- subdivide land or strata subdivide a building;
- carry out earthworks, excavation or filling; and
- carry out development relating to a heritage item listed under the Woollahra LEP 1995.

* The items that are required to be included in an application are detailed in Council's Development Application Guide. Other matters, such as the application fee, will need to be confirmed with Council prior to lodgement.

Some minor developments in the above categories are able to be carried out subject to Council's Exempt and Complying Development DCP. For developments that do require development consent, development application forms are available from Council and must be completed before Council will assess the application.

Development applications are assessed by Council under the *Environmental Planning and Assessment Act 1979*. Council assesses applications on their merits having regard to the NC DCP. However, compliance with the NC DCP does not guarantee Council's approval. Other factors included in section 79C of the *Environmental Planning and Assessment Act 1979* must also be taken into account.

2.1 WHEN IS AN APPLICATION REQUIRED?

2.2 THE ASSESSMENT PROCESS

Section 79C provides five matters for consideration in determining a development application:

- (a) the provisions of:
 - (i) any environmental planning instrument, and
 - (ii) any draft environmental planning instrument that is or has been placed on public exhibition and details of which have been notified to the consent authority, and
 - (iii) any development control plan, and
 - (iv) the regulations (to the extent that they prescribe matters for the purposes of this paragraph)

that apply to the land to which the development application relates,
- (b) the likely impacts of that development, including environmental impacts on both the natural and built environments, and social and economic impacts in the locality,
- (c) the suitability of the site for the development,
- (d) any submissions made in accordance with this Act or the regulations,
- (e) the public interest.

2.3 HOW ARE

APPLICATIONS

DETERMINED?

Council has criteria that determine when and how an application will be advertised and notified. Please refer to Council's Advertising and Notification of Development Applications DCP.

Development applications can be determined by Council in one of four ways, depending on the significance of the proposal, the level of non-conformity with Council's development controls and the incidence of objections received:

- delegated determination by a Council officer;
- determination by the Application Assessment Panel (AAP), which comprises senior Council officers;
- determination by the Development Control Committee (DCC), which comprises Councillors; or
- determination by a meeting of the full Council.

Before lodging a development application, applicants must also consider whether their proposal will require other approvals in addition to Council's development consent. Agencies from which you may need to obtain approval include:

- Heritage Council of NSW;
- Department of Planning;
- Department of Environment and Conservation (incorporating Environment Protection Authority) and National Parks and Wildlife Service; and
- Roads and Traffic Authority.

Council's Development Application Guide can help applicants to identify other approvals that may be necessary.

P A R T

3

Retail Context

PART 3

Traditionally retail hierarchies have a single dominant major centre. Although Woollahra municipality does not have a regional shopping centre, its residents are close to two major centres at Bondi Junction and Sydney CBD. The municipality is unusual in that it also has three district centres, at Double Bay, Rose Bay and Edgecliff.

In traditional retail hierarchies local or neighbourhood centres primarily provided convenience level services to the immediate surrounding residential area. This is still the case in centres like Rose Bay North, Plumer Road in Rose Bay and Vaucluse Shopping Village. Other centres, such as Edgecliff Road and Queen Street Woollahra provide some traditional services but also cater to a specialist regional or even metropolitan market. Similarly Oxford Street offers boutique clothes shopping to a regional market.

Over the past 15 years retail trends in Australia have generally had an adverse impact on the local neighbourhood shopping centres. There has been a general decline in the significance of these centres within the overall retail hierarchy, but at the same time many non-retail services have successfully established in the neighbourhood centres.

The future health and vitality of Woollahra's neighbourhood centres needs to be considered in the context of the general retailing trends. These include:

- Expanded trading hours in large centres which has removed the competitive advantage of local shops, which used to be open when larger centres were closed.
- The increasing size and sophistication of supermarkets in larger centres which has reduced the custom of supermarkets, grocers and fresh food retailers in local centres.
- The increasing number of convenience stores that attract custom away from neighbourhood centres.
- Petrol price rebating by major supermarkets which reduces the competitive strength of smaller and independent supermarkets in neighbourhood centres.
- The withdrawal of local centre services like banks, post offices and financial institutions.
- The increasing reliance on the car which has reduced the patronage of neighbourhood centres located at bus and rail stops.
- Changing lifestyles and the increasing demand for local cafés and restaurants as places for meeting, socialising and casual eating.

In the Woollahra municipality, many of the neighbourhood centres have responded to these trends and introduced personal services (hairdressers, beauticians etcetera), or local business services (accounting, computing, graphic design and the like), as well as cafes and restaurants and specialised food related services. Other local centres have developed as specialty retailing areas for homewares, giftware, antiques, fine art or fashion.

3.1 RETAIL HIERARCHY IN WOOLLAHRA

3.2 RETAIL TRENDS AND NEIGHBOURHOOD CENTRES

3.3

**NEIGHBOURHOOD
CENTRES
PERFORMANCE**

Each of the Neighbourhood Centres across the Woollahra municipality has substantially different threats and opportunities with respect to long term retail performance. The Neighbourhood Centres DCP reflects the place-based approach to precinct and retail analysis that has been undertaken in response to the particular characteristics of each centre. The objectives and controls of the Neighbourhood Centres DCP have been established to support the long term retail and/or commercial health of each local neighbourhood shopping centre and to enhance the mix of local services.

PART
4

Precinct controls

PART 4

Introduction

Each section in Part 4 represents an individual "character precinct". This NC DCP contains precinct controls for eleven individual precincts. Figure 1.3 on page 4 shows the precincts. In part 4, applicants need only refer to the individual precinct that is relevant to their site.

The controls for each character precinct comprise four elements:

- a precinct map showing the land to which specific objectives and performance criteria apply;
- a brief description of the precinct;
- a set of desired future character objectives for the precinct; and
- performance criteria which apply to the precinct.

The desired future character objectives for each precinct describe the outcomes that are required to be achieved through development within the precinct. In order to gain Council approval, developments need to demonstrate that they have fulfilled the relevant objectives.

The performance criteria describe specific ways in which the desired future character objectives can be met. In particular, the performance criteria for each precinct require developments to preserve or enhance the important character elements for the precinct, where these are relevant to the site.

**4.1
HOPETOUN AVENUE
VAUCLUSE**

**Figure 4.1.1:
HOPETOUN AVENUE
PRECINCT MAP**

LEGEND

-  Extent of Neighbourhood Centres DCP
-  Neighbourhood business zone 3(c)
-  Significant views and vistas
-  Street section

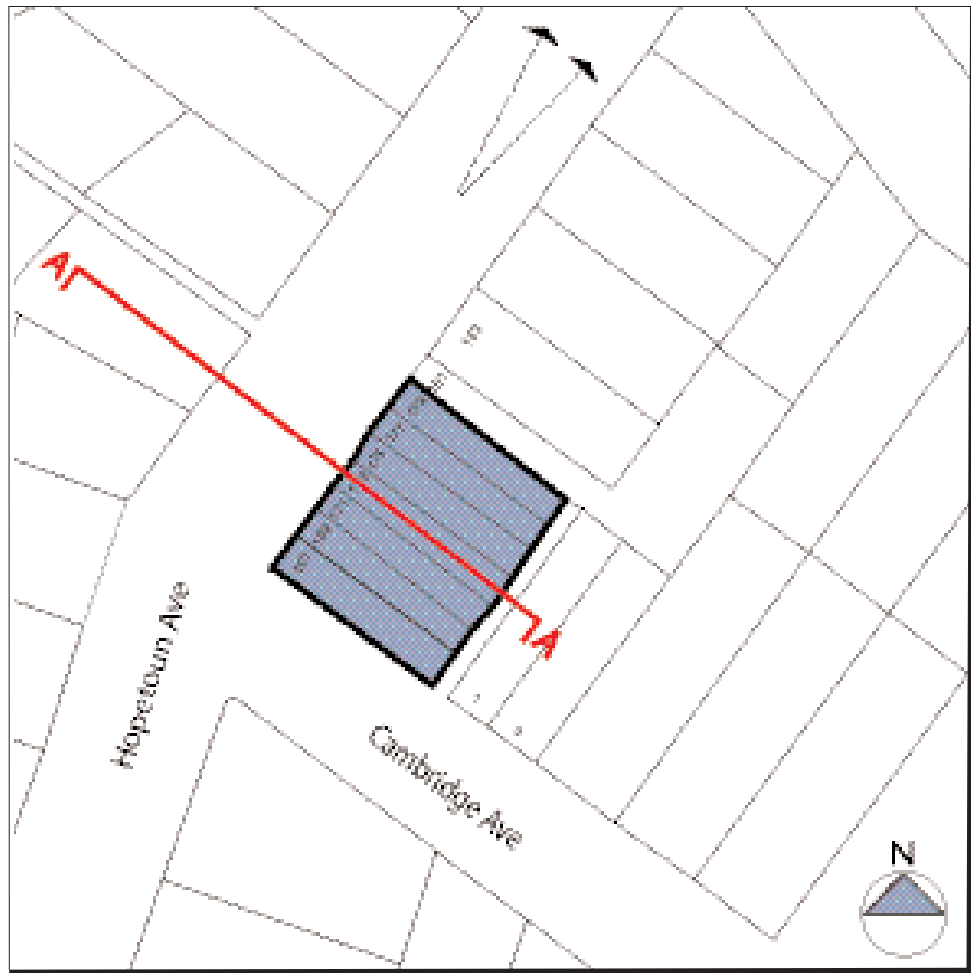

The Neighbourhood Centre is located on an elevated slope on Hopetoun Ave, at the corner of Cambridge Street Vacluse, and is within a kilometre of Watson’s Bay. It is a very small centre with only 6 premises including one general store servicing the local area.

Historical Development

Land in and near the centre was subdivided in the early 1900s with access gained by ferry landing at Parsley Bay or near Gibson Reserve. Larger waterfront blocks were released and built upon first. Substantial housing development followed in the twenties and thirties, whilst Vacluse Council resisted residential flat building in the municipality. The nearby Vacluse Primary School opened in 1925.

Built Form

The building stock around the centre is represented by larger detached residential dwellings of generally high quality and set in generous gardens. The centre comprises a short row of inter-war two-storey shoptop housing, with a recent three storey conversion to the corner property. The shoptop buildings are all built to the street alignment with continuous awnings and parapets.

Heritage and Contributory Buildings

167-171 Hopetoun Avenue, 173-179 Hopetoun Avenue – two shoptop housing groups that form a cohesive streetwall and establish the scale and character of the centre.

Public Parks and Community Facilities

Gibson Park and the police station, Parsley Bay Reserve and Vaucluse Primary School are located close by the centre.

Public Domain

The asphalt footpath and minimal street furniture provide a very basic standard of pedestrian amenity.

Access and Circulation

The centre is on the Watsons Bay bus route, although most shoppers would use car transport or arrive on foot from nearby residences. On street parking is more than adequate for the low levels of retail activity.

Views and Aspect

The centre enjoys a pleasant elevated north-westerly aspect. The church steeple of Our Lady Star of the Sea on New South Head Road at Watsons Bay provides a landmark when looking north along Hopetoun Avenue.

**HOPETOUN AVENUE
VAUCLUSE**

**Hopetoun Avenue and
Cambridge Street**

**HOPETOUN AVENUE
VAUCLUSE**

Desired Future Character Objectives – Hopetoun Avenue Neighbourhood Centre

- O 4.1.1** To support local retail services, office uses and a café.
- O 4.1.2** To protect the fabric and character of the existing inter-war shoptop buildings.
- O 4.1.3** To retain a coherent streetscape with a consistent street wall and parapet line.
- O 4.1.4** To improve and extend the pedestrian environment and to encourage appropriate *al fresco* uses with good solar access.

Desired Future Character Performance Criteria – Hopetoun Avenue Neighbourhood Centre

- C 4.1.1** Development supports the adaptive re-use of existing shoptop units.
- C 4.1.2** Development is a maximum of three storeys in height.
- C 4.1.3** Development **does not** include vehicular access off Hopetoun Avenue.
- C 4.1.4** Development **does not** include infill of original verandahs.
- C 4.1.5** Development maintains the views and vista corridors identified on the precinct map.
- C 4.1.6** Development protects existing street trees and includes streetscape improvements.

**HOPETOUN AVENUE
VAUCLUSE**

Hopetoun Avenue Section

Development conforms to the requirements detailed in the annotated street section below, that indicates the existing street context and illustrates the desired future character for the centre.

C 4.1.7 STREET LANDSCAPE

Development includes advanced tree planting as part of a formal row of shade trees in a widened footpath.

C 4.1.8 STREET AWNING

Development includes a continuous solid suspended awning over the public footpath and along the return into Cambridge Street (see Part 5)

C 4.1.9 STREET WALL

Development retains 2 storeys built to the street alignment, as well as the continuous parapet line.

C 4.1.10 FRONT SETBACK

Development on the third level is setback from the street boundary as shown.

C 4.1.11 BUILDING ARTICULATION

Building articulation at the street alignment is in the form of recessed balconies or loggia only; and elsewhere it is in the form of verandahs, balconies, loggia or wall offsets.

C 4.1.12 OCCUPIABLE AREA

Development uses a maximum of 50% of the potential building envelope as occupiable area.

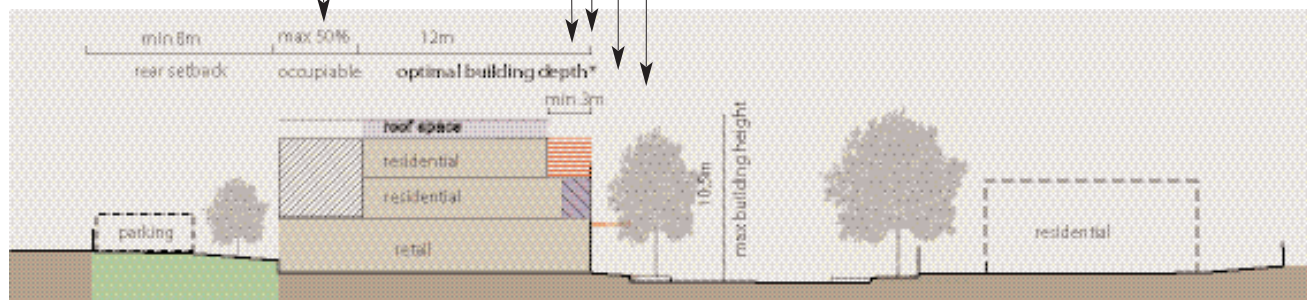

Lane
min 15% site area = deep soil zone

Hopetoun Ave

South side

North side

* Refer to Part 5.3.2
The maximum height of development in metres is determined by the height controls in Woollahra LEP 1995.

4.2
**SOUTH HEAD
 ROUNDABOUT
 VAUCLUSE**

Figure 4.2.1:
**SOUTH HEAD ROUNDABOUT
 PRECINCT MAP**

LEGEND

-  Extent of Neighbourhood Centres DCP
-  Neighbourhood business zone 3(c)
-  Significant views and vistas
-  Commercial site



South Head Roundabout shops are located on New South Head Road at the junction with Old South Head Road. The centre provides a small selection of specialty retail and personal services.

Historical Development

New South Head Road was constructed as a link to Watsons Bay during the 1830's. The South Head Cemetery was dedicated in 1845. Land in and near the centre was subdivided in the early 1900s at the same time as a tramline along New South Head Road was introduced. However, substantial housing development did not proceed until the twenties and thirties. Vacluse Council resisted residential flat building in the municipality, but there were some Inter-war flat buildings built on New South Head Road near the centre. Vacluse High School adjacent to the centre opened in 1960; the same year that the tram service ceased.

Built Form

The Neighbourhood Centre is contained in a single well-conserved Inter-war building, that includes a sympathetic third floor addition for residential use. The buildings address the corner at the roundabout as well as New South Head Road and have a continuous parapet line and a series of canvas awnings. Across the roundabout in Waverley municipality is a mix of twentieth century architecture of varying quality and scale.

Heritage and Contributory Buildings

The Inter-war building housing the Centre at 145-161 New South Head Road provides a significant landmark at this broad open intersection. It is a good intact example of the ocean liner style, although the original face brickwork has been painted and the original awning removed.

Public Parks and Community Facilities

South Head Cemetery and the site of the former Vaucluse High School are adjacent to the centre. Christison Park is close by to the north and east.

Public Domain

The standard asphalt footpath pavement and the exposed corner situation on the roundabout afford little pedestrian amenity.

Access and Circulation

The centre is well located on bus routes operating on both New South Head Road and Old South Head Road. It is readily accessible by car with a limited number of on-street car parking spaces. The speed and volume of vehicles moving through the roundabout compromise pedestrian amenity and safety.

Views and Outlook

The centre has a distant outlook to Christison Park.

Desired Future Character Objectives – South Head Roundabout

- 0 4.2.1** To support a range of specialty retail and personal services.
- 0 4.2.2** To protect the fabric and character of the existing inter-war building.
- 0 4.2.3** To retain a coherent streetscape with a consistent street wall and parapet line.
- 0 4.2.4** To improve the pedestrian environment and connections to commercial activity on the eastern side of the roundabout.

**SOUTH HEAD
ROUNDBABOUT
VAUCLUSE**



**New South Head Road and
Old South Head Road**

**SOUTH HEAD
ROUNDAABOUT
VAUCLUSE****Desired Future Character Performance Criteria – South Head Roundabout**





- C 4.2.1** Development is sympathetic to the existing character and fabric of the inter-war building.
- C 4.2.2** Development supports adaptive re-use of existing retail units at 145-161 New South Head Road.
- C 4.2.3** Development is a maximum of three storeys in height.
- C 4.2.4** Development re-instates the fixed stepped awning, on its original alignment, to the facade of 145-161 New South Head Road.
- C 4.2.5** Development improves the existing landscape treatment and includes streetscape improvements.

4.3
VAUCLUSE
SHOPPING VILLAGE

Figure 4.3.1:
VAUCLUSE SHOPPING
VILLAGE PRECINCT MAP



LEGEND

-  Extent of Neighbourhood Centres DCP
-  Neighbourhood business zone 3(c)
-  Significant views and vistas
-  Street section
-  Key corner site See Part 5.3.25

Vacluse Shopping Village is located on the ridgeline on a curved section of New South Head Road. It provides a mix of local centre goods and services.

Historical Development

New South Head Road was constructed as a link to Watsons Bay during the 1830's. The Shaftesbury Institution was opened on the site of the former Vacluse High School and Samuel Park in 1880. Land in and near the centre was subdivided in the early 1900s at the same time as a tram line along New South Head Road was introduced. However, substan-

VAUCLUSE**SHOPPING VILLAGE**

**New South Head and
Laguna Avenue**

tial housing development did not proceed until the twenties and thirties. Vacluse Council resisted residential flat building in the municipality, but there were some Inter-war flat buildings built on New South Head Road near the centre. The former Vacluse High School opened in 1960, the same year that the tram service ceased.

Built Form

The building stock in and around the centre is represented by a cross section of twentieth century architecture of varying quality. The centre is characterised by two storey shoptop housing, with a recently completed three storey development on the west side. The buildings are generally street addressing with continuous awnings and parapets or hipped rooflines.

Heritage and Contributory Buildings

There are no heritage or contributory buildings in the centre.

Public Parks and Community Facilities

Samuel Park and the former Vacluse High School site are located close by the centre.

Public Domain

The recently completed streetscape works provide a good standard of pedestrian amenity.

Access and Circulation

The centre is on the Watsons Bay bus route, although most shoppers are reliant on car transport and turnover of on-street car parking spaces. Pedestrian movement and safety is compromised by the restricted sightlines on New South Head Road.

Views

The water tower in Clairvaux Road provides a backdrop to the south facing view of the centre along New South Head Road.

Desired Future Character Objectives – Vaucluse Shopping Village

- O 4.3.1** To support a range of local retail and personal services.
- O 4.3.2** To develop a coherent streetscape with a consistent street wall.
- O 4.3.3** To express the gentle curve of New South Head Road.
- O 4.3.4** To define and reinforce the corner sites in the centre.
- O 4.3.5** To improve the architectural quality of building stock.
- O 4.3.6** To facilitate improved pedestrian movement across New South Head Road.
- O 4.3.7** To protect identified views within the centre.

Desired Future Character Performance Criteria – Vaucluse Shopping Village

- C 4.3.1** Development is a maximum of three storeys at the New South Head Road frontage.
- C 4.3.2** Development **does not** include vehicular access off New South Head Road.
- C 4.3.3** Development maintains the views and vista corridors identified on the precinct map.
- C 4.3.4** Development protects existing street trees and includes streetscape improvements.

VAUCLUSE
SHOPPING VILLAGE

New South Head Road Section

Development conforms to the requirements detailed in the annotated street section below, that indicates the existing street context and illustrates the desired future character for the centre.

C 4.3.5 STREET LANDSCAPE

Development includes advanced tree planting in the footpath.

C 4.3.6 STREET WALL AND PARAPET LINE

Development provides 2 storeys built to the street alignment for properties 26, 28, 30, 32, 34 and 36 New South Head Road, and 3 storeys built to the street alignment elsewhere, with a continuous and consistent parapet line above.

C 4.3.7 BUILDING ARTICULATION

Building articulation at the street alignment is in the form of recessed balconies or loggia only; and elsewhere it is in the form of verandahs, balconies, loggia or wall offsets.

C 4.3.8 OCCUPIABLE AREA

Development uses a maximum of 50% of the potential building envelope as occupiable area.

C 4.3.9 STREET AWNING

Development includes a continuous solid suspended awning over the public footpath of New South head Road and along the secondary frontage of corner sites (see Part 5)

C 4.3.10 CORNER SITES

Development on corner sites provides 3 storeys built to the street alignment with a continuous and consistent parapet line above.

C 4.3.11 UPPER LEVEL SETBACK

Development at 26, 28, 30, 32, 34 and 36 New South Head Road (not shown in section below) provides an upper level setback of at least 1.2m for at least 80% of the frontage, where setback walls are aligned parallel to the street boundary.

C 4.3.12 HEIGHT ON WEST SIDE:

Development does not exceed 12 m in height and does not exceed 3 storeys above ground level .

C 4.3.13 BUILDING FORM:

Building form responds to the fall of the land.

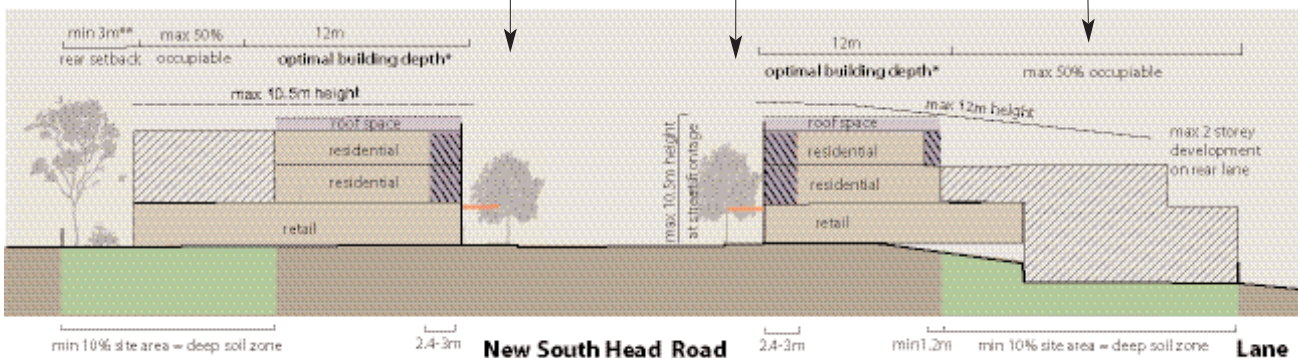

East side

West side

* Refer to Part 5.3.2

** Refer to Part 5.3.18

The maximum height of development in metres is determined by the height controls in Woollahra LEP 1995.

4.4
ROSE BAY NORTH

Figure 4.4.1:
ROSE BAY NORTH
PRECINCT MAP

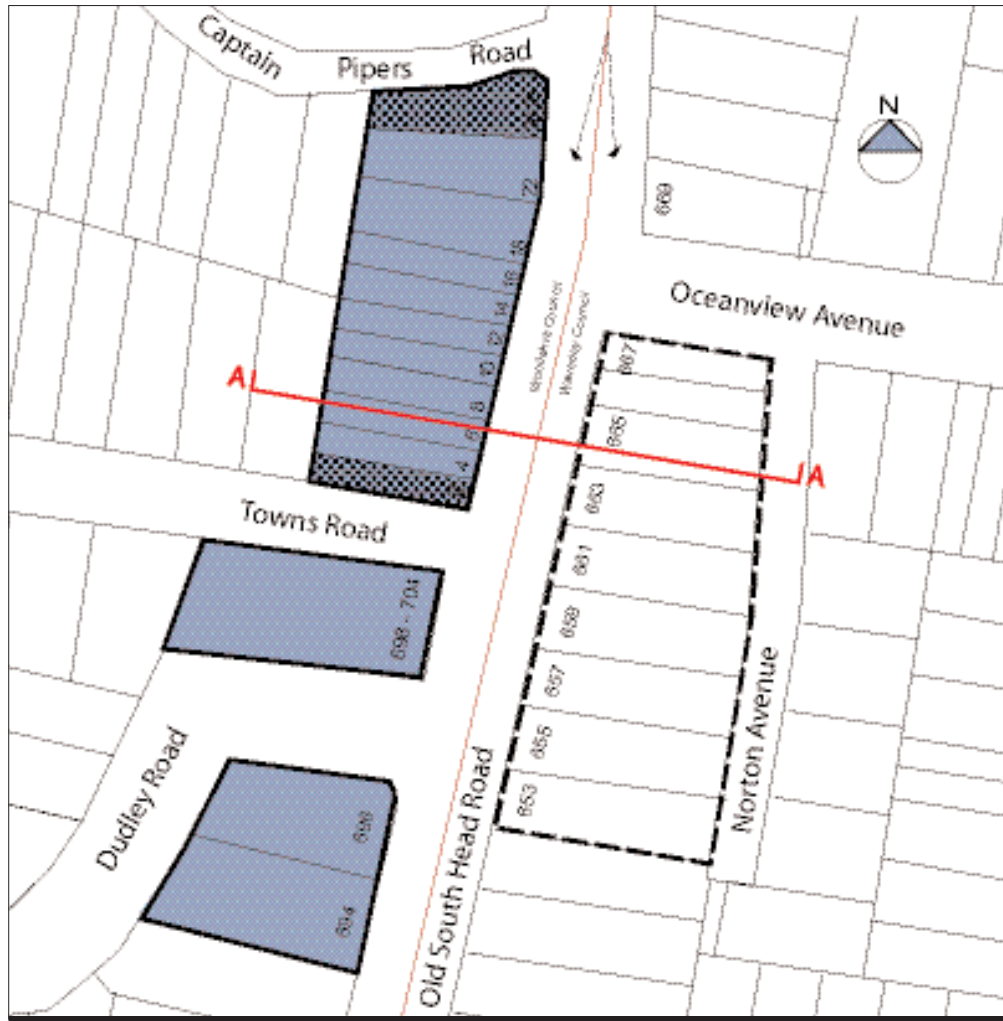

LEGEND

-  Extent of Neighbourhood Centres DCP
-  Neighbourhood business zone 3(c)
-  Significant views and vistas
-  Commercial area
-  Street section
-  Key corner site See Part 5.3.25

Rose Bay North shopping centre is located on Old South Head Road at the junction of the suburbs of Vacluse, Rose Bay and Dover Heights. Old South Head Road forms the boundary between Woollahra and Waverley Councils. The centre has a sizeable catchment and provides a good range of services and facilities for local residents.

Historical Development

Old South Head Road was formed in 1811 to provide access to the signal station at Watsons Bay. The tram was extended along Old South Head Road in 1903 and this was followed by the subdivision of larger estates into town allotments in the 1920s and 1930s. The Kings Theatre was constructed on the corner of Dudley Street and Old South Head Road in 1935 which indicates that the centre was a commercial hub at that time.

ROSE BAY NORTH

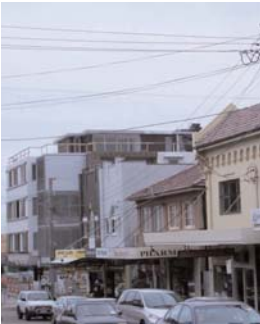

New South Head Road and Towns Road

Built Form

The centre is characterised by two to four storey shoptop buildings. The buildings are generally street addressing with continuous awnings.

Heritage and Contributory Buildings

The former Kings Theatre at 694-696 Old South Head Road was built in 1935 in the Art Deco style. It is a strong corner building and contributes to the character of the centre.

Public Parks and Community Facilities

There are no community facilities or public parks in the centre.

Public Domain

The centre has reasonable pedestrian amenity with continuous awnings and unit paving.

Access and Circulation

The centre is well served by buses and is located on a bike route. Rear lane access for service vehicles is available from Norton Avenue.

Views

The centre is located at the top of a south facing slope and has a distant view of Bellevue Hill.

Desired Future Character Objectives – Rose Bay North Neighbourhood Centre

- O 4.4.1** To support a range of local retail services.
- O 4.4.2** To achieve a consistent built form on both sides of Old South Head Road.
- O 4.4.3** To support the evolution of building styles through the introduction of well designed contemporary buildings.
- O 4.4.4** To provide a mix of housing with ready access to public transport.
- O 4.4.5** To encourage strong corner buildings at the intersection of Towns Road and Dudley Road.
- O 4.4.6** To protect views from the public spaces within the centre to the surrounding district.
- O 4.4.7** To improve the pedestrian environment.

Desired Future Character Performance Criteria – Rose Bay North Neighbourhood Centre

- C 4.4.1** Development is a maximum of four storeys.
- C 4.4.2** Development **does not** include vehicular access from Old South Head Road.
- C 4.4.3** Development maintains the views and vista corridors identified on the precinct map.
- C 4.4.4** Development includes streetscape improvements.

ROSE BAY NORTH

Old South Head Road Section

Development conforms to the requirements detailed in the annotated street section below, that indicates the existing street context and illustrates the desired future character for the centre.

C 4.4.5 STREET AWNING

Development includes a continuous solid suspended awning over the public footpath of Old South Head Road and along the secondary frontage of corner sites (see Part 5).

C 4.4.10 STREET LANDSCAPE

Development includes advanced tree planting in the footpath.

C 4.4.6 STREET WALL AND PARAPET LINE

Development provides 3 storeys built to the street alignment, with a continuous and consistent parapet line above.

C 4.4.11 CORNER SITES

Development on corner sites provides 4 storeys built to the street alignment with a continuous and consistent parapet line above.

C 4.4.7 FRONT SETBACK

Development on the fourth level is setback from the street boundary as shown.

C 4.4.8 BUILDING ARTICULATION

Building articulation at the street alignment is in the form of recessed balconies or loggia only; and elsewhere it is in the form of verandahs, balconies, loggia or wall offsets.

C 4.4.9 OCCUPIABLE AREA

Development uses a maximum of 50% of the potential building envelope as occupiable area.

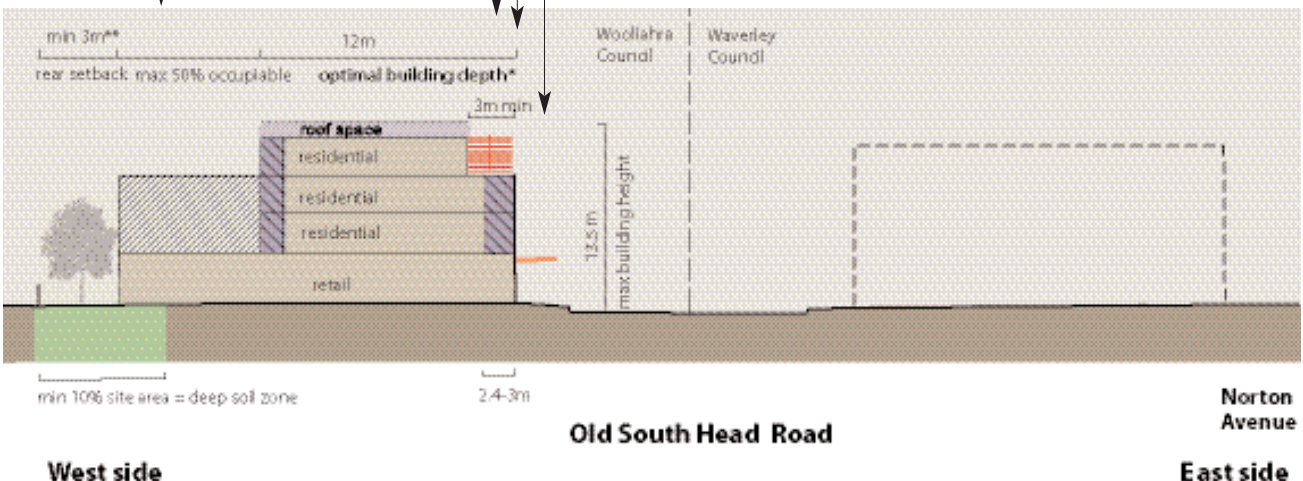

West side

East side

* Refer to Part 5.3.2

** Refer to Part 5.3.18

The maximum height of development in metres is determined by the height controls in Woollahra LEP 1995.

4.5
ROSE BAY SOUTH

Figure 4.5.1:
ROSE BAY SOUTH
PRECINCT MAP

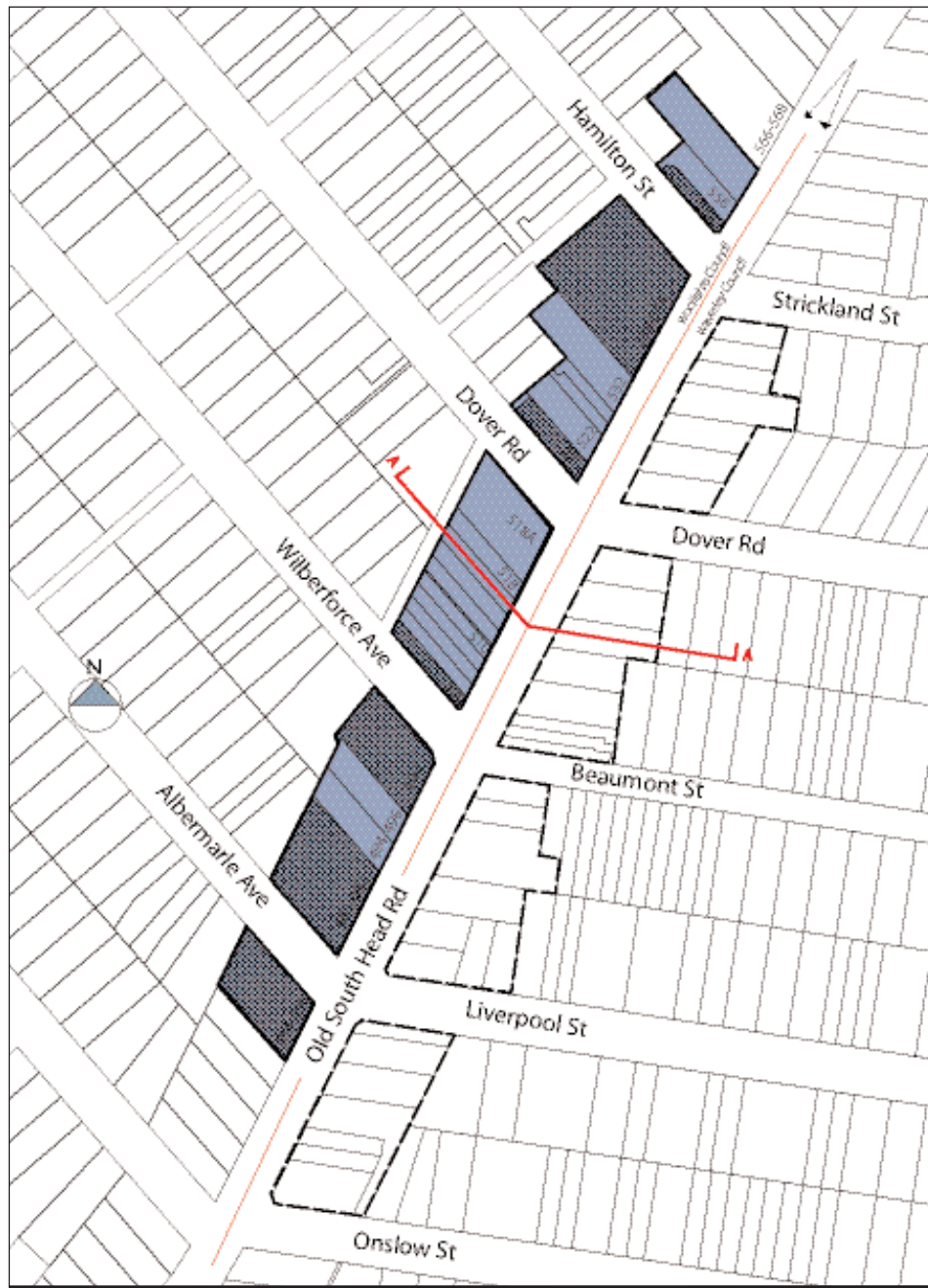

LEGEND

-  Extent of Neighbourhood Centres DCP
-  Neighbourhood business 3(c)
-  Significant views and vistas
-  Commercial area
-  Street section
-  Key corner site see Part 5.3.25

Rose Bay South shopping centre is less than 2km from the Rose Bay Centre travelling east along Dover Road. It extends over at least four blocks along Old South Head Road (which forms the boundary between Woollahra and Waverley Council areas). The centre provides a good mix of services as well as a range of health services for local residents.

ROSE BAY SOUTH

**Old South Head Road and
Dover Road**

Historical Development

Old South Head Road was formed in 1811 to provide access to the signal station at Watsons Bay. The tram was extended along Old South Head Road in 1903 and this was followed by the subdivision of larger estates into town allotments in the 1920s and 1930s. The Rose Bay Uniting church and hall at the corner of Dover Road and Old South Head Road was constructed in 1924.

Built Form

The centre is characterised by two and three storey shoptop housing. The buildings are generally street addressing with continuous awnings. The row of Inter-war 2 storey shops between Wilberforce and Hamilton Streets are characterised by strong rectilinear parapet lines, continuous awnings and shopfronts built to the street alignment.

Heritage and Contributory Buildings

The Uniting Church at 518A Old South Head Road provides a local landmark at the Dover Road intersection.

Public Parks and Community Facilities

The church, adjacent hall and the kindergarten are a focus for community activity.

Public Domain

The centre has reasonable pedestrian amenity with continuous awnings and unit paving. Street tree planting is minimal and scattered mostly at the southern end.

Access and Circulation

The centre is well served by buses and is located on a bike route. Rear lane access for service vehicles is available between Wilberforce Avenue and Dover Road and from Short Lane off Hamilton Street.

Views

The centre is located on a south facing slope and has a distant view of Bellevue Hill.

Desired Future Character Objectives – Rose Bay North Neighbourhood Centre

- 0 4.5.1** To support a range of local retail and personal services.
- 0 4.5.2** To support the evolution of building styles through the introduction of well designed contemporary buildings.
- 0 4.5.3** To provide of a mix of housing with ready access to public transport.
- 0 4.5.4** To achieve a consistent built form on both sides of Old South Head Road.

- O 4.5.5** To define and reinforce corner sites in the centre.
- O 4.5.6** To support redevelopment of the key site at the intersection Wilberforce Avenue and Old South Head Road.
- O 4.5.7** To protect views and vistas within the centre.
- O 4.5.8** To improve the pedestrian environment.

Desired Future Character Performance Criteria – Rose Bay South Neighbourhood Centre

- C 4.5.1** Development is a maximum of four storeys.
- C 4.5.2** Development **does not** include vehicular access from Old South Head Road.
- C 4.5.3** Development maintains the views and vista corridors identified on the precinct map.
- C 4.5.4** Development includes streetscape improvements.

ROSE BAY SOUTH

Old South Head Road Section

Development conforms to the requirements detailed in the annotated street section below, that indicates the existing street context and illustrates the desired future character for the centre.

C 4.5.5 STREET AWNING

Development includes a continuous solid suspended awning over the public footpath of Old South Head Road and along the secondary frontage of corner sites (see Part 5).

C 4.5.10 STREET LANDSCAPE

Development includes advanced tree planting in the footpath.

C 4.5.6 STREET WALL AND PARAPET LINE

Development provides 3 storeys built to the street alignment, with a continuous and consistent parapet line above.

C 4.5.11 CORNER SITES

Development on corner sites provides 4 storeys built to the street alignment with a continuous and consistent parapet line above.

C 4.5.7 FRONT SETBACK

Development on the fourth level is setback from the street boundary as shown.

C 4.5.8 BUILDING ARTICULATION

Building articulation at the street alignment is in the form of recessed balconies or loggia only; and elsewhere it is in the form of verandahs, balconies, loggia or wall offsets.

C 4.5.9 OCCUPIABLE AREA

Development uses a maximum of 50% of the potential building envelope as occupiable area.

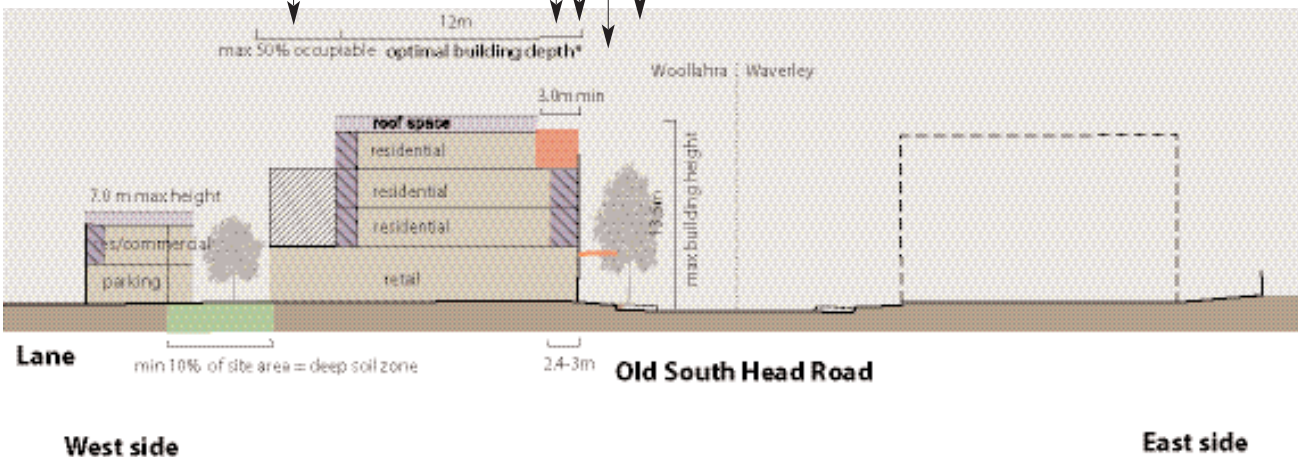

* Refer to Part 5.3.2
The maximum height of development in metres is determined by the height controls in Woollahra LEP 1995.

**4.6
PLUMER ROAD
ROSE BAY**



**Figure 4.6.1:
PLUMER ROAD PRECINCT
MAP**

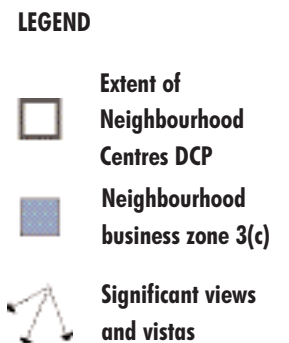

The Plumer Road shopping centre is located at the intersection of Plumer and O'Sullivan Roads opposite Woollahra Park. The area has flat topography and is characterised by the mature planting of fig trees along O'Sullivan Road. The shopping centre is located within the Balfour Road Heritage Conservation Area. The centre provides an excellent mix of goods and services for the local community.

Historical Development

Speculation to create an exclusive Marine Estate along the esplanade at Rose Bay was commenced in the 1830s, but apart from the 1835 construction of Rose Bay Lodge (in what is now Salisbury Road), the district remained substantially undeveloped throughout the 19th century. More intensive subdivision of the land surrounding Rose Bay Lodge commenced after the introduction of the Rose Bay tram service in 1903, but again development in the area was slow.

The Plumer Road shops were part of the Beresford Estate and were subdivided over the period from 1925-1928 as business sites. Early flat development in the area and one of the blocks of shops in Plumer Road occurred in the early to mid 20's. The Balfour Road Heritage Conservation Area represents the intensified residential development of Rose Bay during the Inter-war period.

**PLUMER ROAD
ROSE BAY**



**Plumer Road and
O'Sullivan Road**

Built Form

Like most buildings in the Balfour Road Heritage Conservation Area, the Plumer Road shops are two and three storey builder's blocks of flats. They are characterised by street wall buildings built to the property boundary in Plumer Road with a setback to O'Sullivan Road. They have continuous awnings and a hipped roof form.

Heritage and Contributory Buildings

Nos 89-93 O'Sullivan Road and 9-23 Plumer Road have been identified in the Balfour Road Precinct Heritage Conservation Area Study as being significant corner elements that form a gateway to the precinct.

Public Parks and Community Facilities

Woollahra Public Golf Course is located immediately opposite the shops on O'Sullivan Road.

Public Domain

The continuous awnings and well maintained concrete footpaths and buildings provide good amenity for pedestrians. The fig tree planting on O'Sullivan Road provides a leafy backdrop to the centre. The setback area on O'Sullivan Road facilitates outdoor dining.

Access and Circulation

The centre is located close by the 326 bus route and the routes on New South Head Road. However, most shoppers access the centre by foot or are reliant on car transport and turnover of on-street car parking spaces.

Views

The centre enjoys views over Woollahra Public Golf Course and an enframed vista to the harbour down O'Sullivan Road.

Desired Future Character Objectives – Plumer Road Shops

- O 4.6.1** To support a range of local retail and personal services.
- O 4.6.2** To maintain the centre as the “gateway” to the Balfour Road Precinct Heritage Conservation Area.
- O 4.6.3** To retain and enhance the contributory buildings and ensure they retain their streetscape context.
- O 4.6.4** To support redevelopment of buildings that detract from the streetscape character.
- O 4.6.5** To maintain the leafy character and ambience of O’Sullivan Road.
- O 4.6.6** To protect identified views within the centre.

Desired Future Character Performance Criteria – Plumer Road Shops

- C 4.6.1** Development supports the adaptive re-use of existing shoptop units.
- C 4.6.2** Development at 95 O’Sullivan Road is a maximum of three storeys in height.
- C 4.6.3** Development at Nos 89-93 O’Sullivan Road and 9-23 Plumer Road maintains existing building height, scale and form.
- C 4.6.4** Development at Nos 89-93 O’Sullivan Road and 9-23 Plumer Road maintains and retains the original fabric of the contributory buildings..
- C 4.6.5** Development maintains the existing building separation pattern to neighbouring residential lots by retaining the existing driveway crossovers for access.
- C 4.6.6** Development is setback from O’Sullivan Road to match existing retail/commercial buildings and does not include structures within the setback area.
- C 4.6.7** Development provides a continuous awning to the street frontage to match existing awnings at 89-93 O’Sullivan Road and 9-23 Plumer Road.
- C 4.6.8** Development provides high amenity *al fresco* dining in the O’Sullivan Road setback area.
- C 4.6.9** Development provides advanced tree planting in the O’Sullivan Road setback area that reinforces and complements the existing avenue of mature trees.

PLUMER ROAD
ROSE BAY

- C 4.6.10** Development maintains the views and vista corridors identified on the precinct map.
- C 4.6.11** Development undertakes streetscape improvements.
- C 4.6.12** New development on 95 O'Sullivan Road presents a similar roof form and pitch as adjoining contributory buildings, when viewed from the public domain.
- C 4.6.13** Development does not include habitable space in the roof structure of existing buildings, and does not include any dormer window.
- C 4.6.14** Any skylights or solar panels are not visible from any street frontage.
- C 4.6.15** Development retains and conserves any original chimneys .
- C 4.6.16** Any replacement of original building fabric is of similar material and type (eg timber for timber etc).
- C 4.6.17** Development does not include any painting, bagging or rendering of original face brickwork.
- C 4.6.18** Development does not include any infill (by glazing or otherwise) of original verandas or balconies.
- C 4.6.19** Development reinstates architectural detailing on significant and contributory buildings as appropriate.
- C 4.6.20** Parking is located at the rear of buildings. No parking spaces or garages are permitted in the front setback area.
- C 4.6.21** Security grilles on windows and doors complement frame and glazing pattern, and are fitted on the inside of windows or doors.
- C 4.6.22** Development retains original window and door hardware.
- C 4.6.23** Any security fly screens are retractible.
- C 4.6.24** New signage is of a compatible design and colour to that existing.

4.7
ROSE BAY WEST

Figure 4.7.1:
ROSE BAY WEST
PRECINCT MAP

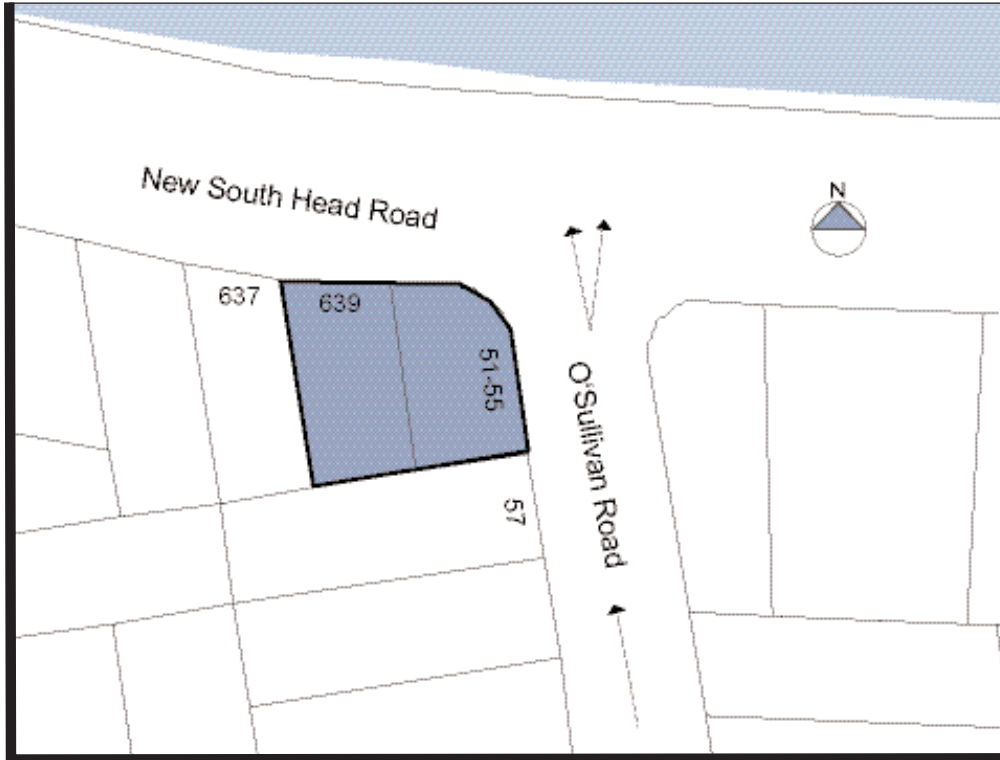

LEGEND

-  Extent of Neighbourhood Centres DCP
-  Neighbourhood business zone 3(c)
-  Significant views and vistas

The O'Sullivan Road Neighbourhood Centre is located on the corner of New South Head and O'Sullivan Roads, overlooking the Rose Bay waterfront and promenade. The area has flat topography and is characterised by the mature planting of Fig Trees along O'Sullivan Road. The centre is close to the Balfour Road Heritage Conservation Area. The centre provides a limited mix of goods and services for the local community and passing motorists.

Historical Development

The Rose Bay area was originally part of the Cooper Estates. Speculation to create an exclusive Marine Estate along the esplanade was commenced in the 1830s, but apart from the construction of Rose Bay Lodge in 1835, the district remained substantially undeveloped throughout the 19th century. More intensive subdivision of the land surrounding Rose Bay Lodge commenced after the introduction of the Rose Bay tram service in 1903, but again development in the area was slow. Early flat development in the area dates from the early to mid 20's. The Balfour Road Heritage Conservation Area represents the intensified residential development of Rose Bay during the Inter-war period.

ROSE BAY WEST



**New South Head Road and
O'Sullivan Road**

The small Neighbourhood Centre occupies land sub-divided from the grounds of Rose Bay Lodge in 1900 and called the Beresford Estate. The three lots created at O'Sullivan and New South Head Roads were subsequently merged and re-subdivided in 1928. In that same year Lot 1 (now 51-55 O'Sullivan Road) was developed as a service station and shops.

Built Form

The O'Sullivan Road shops occupy a single storey Spanish Mission style corner building with driveway apron (that was previously a garage and service station), and a two storey late 20th century built to the New South Head street alignment. Surrounding buildings are typically three storey brick builder's blocks of flats with hipped roof form, setback from the boundary on both O'Sullivan Road and New South Head Road.

Heritage and Contributory Buildings

The Spanish Mission style building has significance as a rare and representative surviving example of early service station architecture influenced by Californian design. The former garage and 'car laundry' have been identified in the Woollahra LEP (Amendment 52) as a heritage item.

Public Parks and Community Facilities

The Rose Bay Promenade runs along New South Head Road to the north and Woollahra Public Golf Course is located immediately opposite the shops on O'Sullivan Road.

Public Domain

The site has excellent north and east sun access and exposure to harbour breezes. High traffic volumes, fragmented pavement areas, lack of street trees or continuous awnings and the poorly defined corner, adversely affect the public domain with its drive-in access.

Access and Circulation

The centre is well served by routes on New South Head Road. However, most shoppers access the centre by car and are reliant on turnover of limited on-street car parking spaces.

Views and Outlook

The centre enjoys broad views over Rose Bay and a green outlook to Woollahra Public Golf Course and tree lined O'Sullivan Road.

Desired Future Character Objectives – O’Sullivan Road Shops

- O 4.7.1** To provide a mix of local retail and personal services.
- O 4.7.2** To protect the fabric, character and significance of the existing Spanish Mission style heritage building.
- O 4.7.3** To provide a high amenity pedestrian and *al fresco* trading area overlooking Rose Bay and the promenade.
- O 4.7.4** To support redevelopment of buildings that detract from the streetscape character.
- O 4.7.5** To enhance the leafy character and ambience of O’Sullivan Road and New South Head Road.
- O 4.7.6** To protect identified views within the centre.
- O 4.5.7** To improve the pedestrian environment.





Desired Future Character Performance Criteria – O’Sullivan Road Shops

- C 4.7.1** Development complies with street sections and building envelopes.
- C 4.7.2** Development is a maximum three storey height.
- C 4.7.3** Development is sympathetic to the existing character and fabric of the Spanish Mission style building.
- C 4.7.4** Development supports adaptive re-use of existing retail units within 51-55 O’Sullivan Road.
- C 4.7.5** Development within 51-55 O’Sullivan Road provides active retail frontage and high amenity *al fresco* trading.
- C 4.7.6** Development maintains the views and vista corridors shown on the Precinct Map.
- C 4.7.7** Development provides street tree planting and streetscape improvements.

4.8
BELLEVUE HILL

Figure 4.8.1
BELLEVUE HILL
PRECINCT MAP

LEGEND

-  Extent of Neighbourhood Centres DCP
-  Neighbourhood business zone 3(c)
-  Significant views and vistas
-  Street section
-  Key corner site See Part 5.3.25

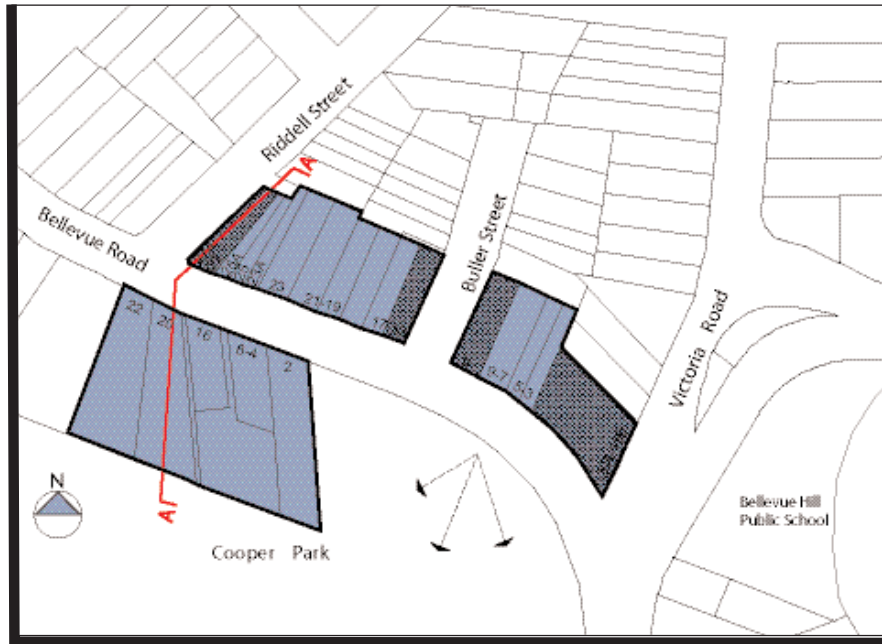

The Bellevue Hill Neighbourhood Centre is located on the ridgeline at the junction of Bellevue Road and Victoria Road (both of which are important urban collector roads linking New South Head and Old South Head Roads). The Centre overlooks the upper extent of Cooper Park to the south. Generally it provides a mix of local centre goods and services.

Historical Development

‘BelleVue’ (now Bellevue Park) was known in the early 19th century for its panoramic views to the harbour and the ocean. The area was then part of the Point Piper Estate, an extensive private land grant to Cooper and Levey. The Bellevue Hill and Bellevue Park Estates were subdivided and re-subdivided from the estate between 1883 and 1912, producing smaller lots on the higher slopes away from the harbour. Following the extension of the tramline along Old South Head Road in 1909 early urban development intensified.

Residential flat blocks were built on larger sites overlooking Cooper Park whilst retail and commercial uses were finally permitted on the northern side of Bellevue Road between Victoria Road and Riddell Street in 1929. The centre has seen a continuous process of development, which has established the existing mix of retail, commercial, residential and institutional uses in a small mixed-use centre. St Stephens Church (1928) and the Bellevue Hill primary School (1925) are located close by on Victoria Road.

Built Form

The building stock in and around the centre is represented by a cross section of twentieth century architecture of varying quality. There are a number of two storey buildings in the Centre dating from the original interwar development. They are typically built to the

boundary with a street parapet line and a deep solid suspended awning over the footway. One three storey Inter-war flatblock remains on the south side. There is one residential tower, developed in the 1960-70s, with a porte cochere to Buller Street. Later development includes three and four storey buildings that typically have a single storey to the street with variable front setbacks at each level. The recent development at 2-16 Bellevue Road is three storeys built to the street alignment. The two detached houses within the commercial zone on Victoria Rd are sited well above the street level and are not well integrated with the centre.

Public Parks and Community Facilities

Bellevue Hill Public School is immediately east of the centre with Bellevue Hill Park beyond. The eastern part of the retail Centre overlooks the extensive gully of Cooper Park, which runs down to Double Bay. There are no community buildings in the Centre.

Public Domain

Pedestrian amenity is variable depending on location of awnings and shade trees, with limited solar access to the main northside footway. At street level there is a variety of building setbacks, alcoves, colonnades and recessed entrances and driveways that could attract anti-social behaviour. Opportunities exist for the improvement of public domain and the creation of a small square or *al fresco* space with a northern aspect.

Access and Circulation

The centre is well served by buses although most shoppers are reliant on car transport and turnover of on-street car parking spaces. Angle parking has been introduced in Riddell Street to increase yield. Generally there is no rear lane access to properties and side street driveway treatments on Buller Street severely compromise pedestrian access and amenity.

Views

Good views of Cooper Park are available from upper levels at the eastern end or on the south side of Bellevue Road.

Desired Future Character Objectives – Bellevue Hill Neighbourhood Centre

- O 4.8.1** To provide a mix of local retail and personal services.
- O 4.8.2** To enhance the visual connections between the centre and Cooper Park.
- O 4.8.3** To redress and strengthen the poorly defined corners in the Centre.
- O 4.8.4** To develop a coherent streetscape with a consistent street wall and consistent upper level setbacks.

BELLEVUE HILL



Bellevue Road and Riddell Street

BELLEVUE HILL

- O 4.8.5** To improve the architectural quality of building stock.
- O 4.8.6** To facilitate improved pedestrian movement across Bellevue Road.
- O 4.8.7** To provide for a small north facing *al fresco* space with good sun access.
- O 4.8.8** To retain ground floor retail and commercial uses on Bellevue Road only.
- O 4.8.9** To protect and extend a coherent street tree planting scheme.

Desired Future Character Performance Criteria – Bellevue Hill Neighbourhood Centre

- C 4.8.1** Development on the north side of Bellevue Road is a maximum of three storeys.
- C 4.8.2** Development on the south side of Bellevue Road is a maximum of three storeys at the street frontage.
- C 4.8.3** Development on the north side of Bellevue Road **does not** include vehicular access from Bellevue Road.
- C 4.8.4** Development includes alteration and additions to 13-17 Bellevue Road to provide a two storey retail or commercial corner unit built to both street alignments.
- C 4.8.5** Development upgrades and reinforces the landmark corner of Victoria and Bellevue Roads through building to the street alignment up to three storeys, improving the awning, increasing frontage glazing and introducing a parapet line.
- C 4.8.6** At the eastern end of Bellevue Road development introduces *al fresco* uses that have an outlook to Cooper Park.
- C 4.8.7** Development maintains the views and vista corridors identified on the precinct map.
- C 4.8.8** Development protects existing street trees and includes streetscape improvements.

BELLEVUE HILL

Bellevue Road Section

Development conforms to the requirements detailed in the annotated street section below, that indicates the existing street context and illustrates the desired future character for the centre.

C 4.8.9 STREET AWNING

Development includes a continuous solid suspended awning over the public footpath of Old South Head Road and along the secondary frontage of corner sites (see Part 5).

C 4.8.10 STREET WALL AND PARAPET LINE (NORTH SIDE)

Development provides 2 storeys built to the street alignment, with a continuous and consistent parapet line above.

C 4.8.11 FRONT SETBACK

Development on the upper levels is setback from the street boundary as shown.

C 4.8.12 BUILDING ARTICULATION

Building articulation at the street alignment is in the form of recessed balconies or loggia only; and elsewhere it is in the form of verandahs, balconies, loggia or wall offsets. Occupy up to 80% of articulation zone with floor area elements or balconies.

C 4.8.13 OCCUPIABLE AREA

Development uses a maximum of 50% of the potential building envelope as occupiable area.

C 4.8.14 STREET LANDSCAPE

Development includes advanced tree planting in the footpath.

C 4.8.15 STREET WALL AND PARAPET LINE (SOUTH SIDE)

Development provides 3 storeys built to the street alignment, with a continuous and consistent parapet line above.

C 4.8.16 CORNER SITES

Development on corner sites provides 4 storeys built to the street alignment with a continuous and consistent parapet line above.

C 4.8.17 RETAIL UNITS - SOUTH SIDE

Development on the south side of Bellevue Road provides full depth retail units that have an elevated outlook over Cooper Park.

C 4.8.18 HEIGHT ON SOUTH SIDE

Development does not to exceed 18 metre in height at the rear and does not exceed 3 storeys at the street frontage.

C 4.8.19 BUILDING FORM:

Building form responds to the fall of the land.

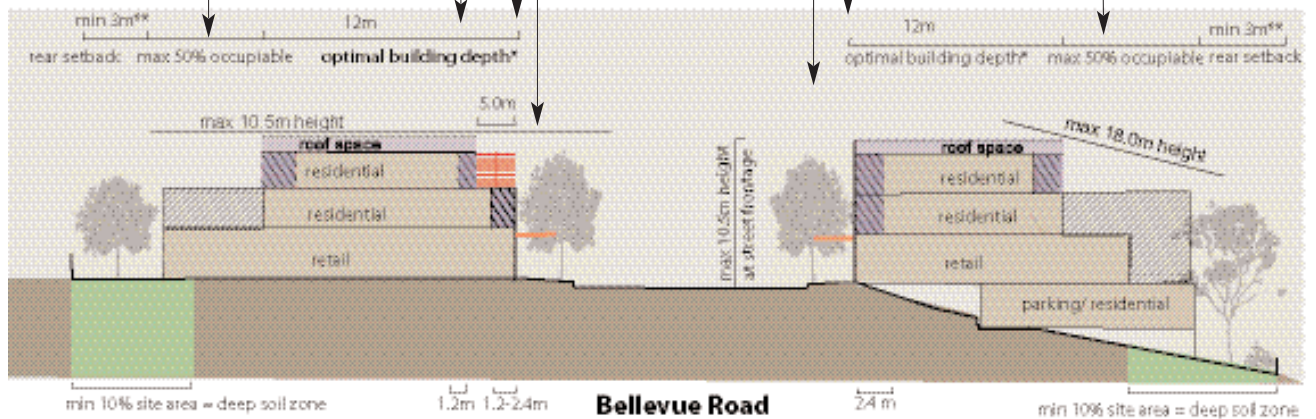

North side

South side

* Refer to Part 5.3.2

** Refer to Part 5.3.18

The maximum height of development in metres is determined by the height controls in Woollahra LEP 1995.

4.9
STREATFIELD ROAD
& BELLEVUE ROAD
BELLEVUE HILL

Figure 4.9.1:
STREATFIELD ROAD
PRECINCT MAP

LEGEND

-  Extent of Neighbourhood Centres DCP
-  Neighbourhood business zone 3(c)
-  Significant views and vistas
-  Street section
-  Key corner site See Part 5.3.25

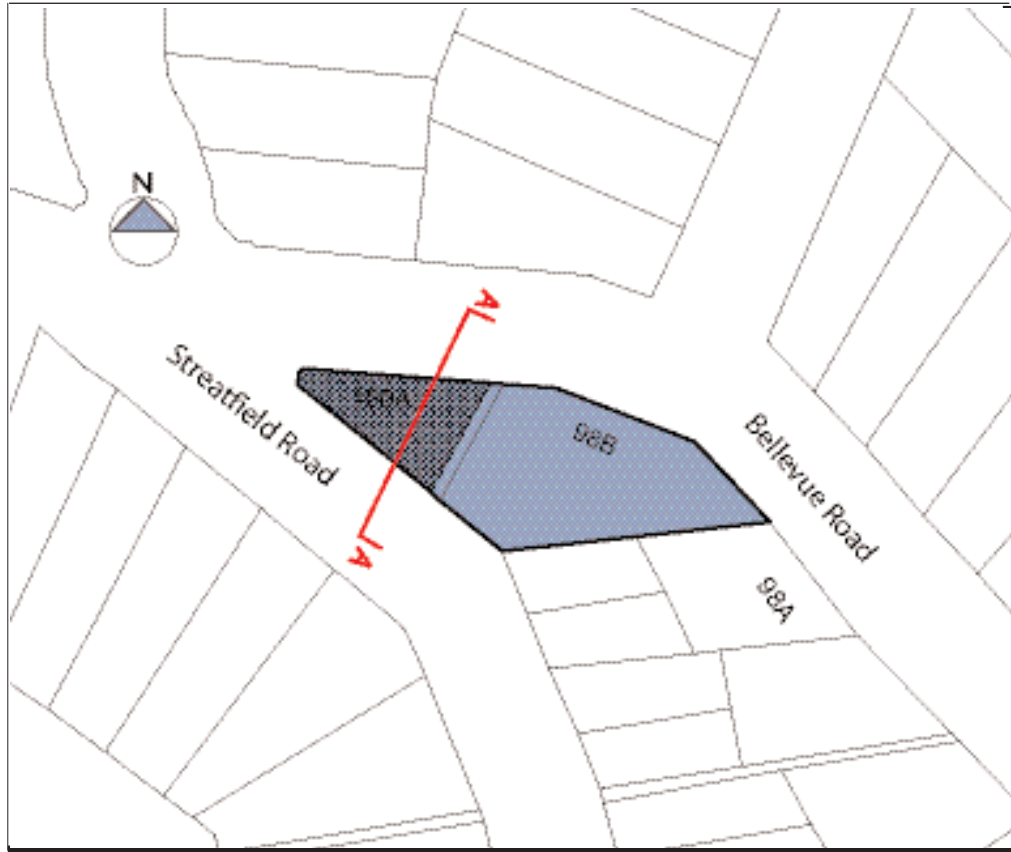

The Streatfield Road Neighbourhood Centre is located on steeply sloping land on the southern side of Bellevue Road, at its junction with Streatfield Avenue Bellevue Hill. The shops provide a small selection of specialty retail and personal services and a cafe.

Historical Development

In the early 19th century the Bellevue Hill area was part of the Point Piper Estate, an extensive private land grant made to Cooper and Levey in 1820. The Bellevue Hill and Bellevue Park Estates were subdivided and re-subdivided from the estate between 1883 and 1912, producing smaller lots on the higher slopes and areas away from the harbour. Following the extension of the tramline along Old South Head Road in 1909 early urban development intensified.

The Streatfield Road centre is located on Point Piper Estate land sub-divided in 1920. The Inter-war building at 98B Bellevue Road was purpose built shoptop housing and dates from 1929. Concurrently commercial uses were also permitted on the northern side of Bellevue Road between Victoria Road and Riddell Street.

Built Form

The Neighbourhood Centre is contained in three buildings: a well-conserved two-three storey Inter-war residential retail complex that follows the curve and grade of Bellevue Road, a single storey flat roof building of poor quality and a two storey cottage on the corner. All buildings address Bellevue Road. Awnings are light weight, poor quality and discontinuous.

Heritage and Contributory Buildings

98 Bellevue Road is an intact face brick inter-war residential retail complex with two storey frontage to Bellevue Road. It is in good condition with much of the external fabric sympathetically maintained. It establishes a strong street wall and parapet line that responds sensitively to the grade and curve of the site and establishes a landmark presence. The original stepped awning has been lost.

Public Domain

The north facing aspect with broad canopy street trees provide good amenity for *al fresco* uses. Footway grade and width restricts extent of useable space.

Access and Circulation

The centre is well located adjacent the bus stop for services operating on Bellevue Road. It is readily accessible by car with a limited number of on-street parking spaces. Pedestrian amenity and safety is compromised by vehicular traffic speeds and limited sight lines on Bellevue Road.

Views and Outlook

The centre has a pleasant outlook along Bellevue Road.

**STREATFIELD ROAD
& BELLEVUE ROAD
BELLEVUE HILL**



**Bellevue Road at
Kambala Road.**

**STREATFIELD ROAD
& BELLEVUE ROAD
BELLEVUE HILL**

Desired Future Character Objectives – Streatfield Road Bellevue Hill

- O 4.9.1** To support a range of local services, specialty retail and personal services.
- O 4.9.2** To protect the fabric and character of the existing Inter-war building at 98B Bellevue Road.
- O 4.9.3** To establish a strong and continuous built form that addresses both Bellevue Road and Streatfield Road at the corner.
- O 4.9.4** To improve the public domain for *al fresco* uses that have good solar access.
- O 4.9.5** To retain a sightline and pedestrian access from Bellevue Road to Streatfield Road.

Desired Future Character Performance Criteria – Streatfield Road Bellevue Hill

- C 4.9.1** Development is a maximum of two storeys in height at Bellevue Road and three storeys in height at Streatfield Road and the corner.
- C 4.9.2** Development supports the adaptive re-use of existing shoptop units at 98B Bellevue Road.
- C 4.9.3** Development re-instates the fixed stepped awning to 98B Bellevue Road.
- C 4.9.4** Development provides a new built form with small scale shopfronts that step with the street grade.
- C 4.9.5** Development on 100A Bellevue Road complements the built form and character of 98B Bellevue Road.
- C 4.9.6** Development on 100A Bellevue Road includes no more than one single width vehicle access crossing that is located on Streatfield Road.
- C 4.9.7** Development maintains a direct sightline and public access way between properties at 98B and 100A Bellevue Road.
- C 4.9.8** Development enhances the amenity of the footpath area.

**STREATFIELD ROAD
& BELLEVUE ROAD**

Bellevue Road to Streatfield Road Section

Development conforms to the requirements detailed in the annotated street section below, that indicates the existing street context and illustrates the desired future character for the centre.

C 4.9.9 STREET AWNING

Development includes a continuous but stepped awning over the public footpath of Bellevue Road and around the corner radius into Streatfield Road (see Part 5)

C 4.9.12 STREET WALL TO BELLEVUE ROAD

Development provides 2 storeys built to the Bellevue Road street alignment, with a continuous and consistent parapet line above.

C 4.9.10 STREET LANDSCAPE

Development includes advanced tree planting in the footpath along both frontages.

C 4.9.13 BUILDING ARTICULATION

At both street frontages occupy at least 80% of the articulation zone with floor area elements or recessed balconies or loggia.

C 4.9.11 DEEP SOIL ZONE **

Development provides deep soil planting area on the boundary with 98B Bellevue Road.

C 4.9.14 STREET WALL AT THE CORNER AND TO STREATFIELD ROAD

Development provides 3 storeys built to the corner radius and the Streatfield Road alignment, with a continuous and consistent parapet line above.

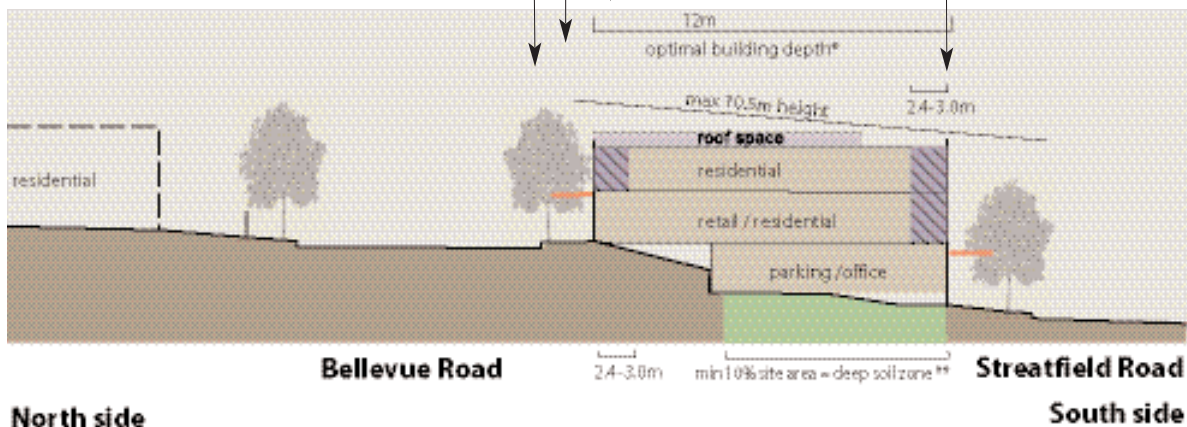

* Refer to Part 5.3.2

The maximum height of development in metres is determined by the height controls in Woollahra LEP 1995.

4.10
MANNING ROAD
WOOLLAHRA

Figure 4.10.1:
MANNING ROAD PRECINCT

- LEGEND**
-  Extent of Neighbourhood Centres DCP
 -  Neighbourhood business zone 3(c)
 -  Significant views and vistas
 -  Commercial use
 -  Street section

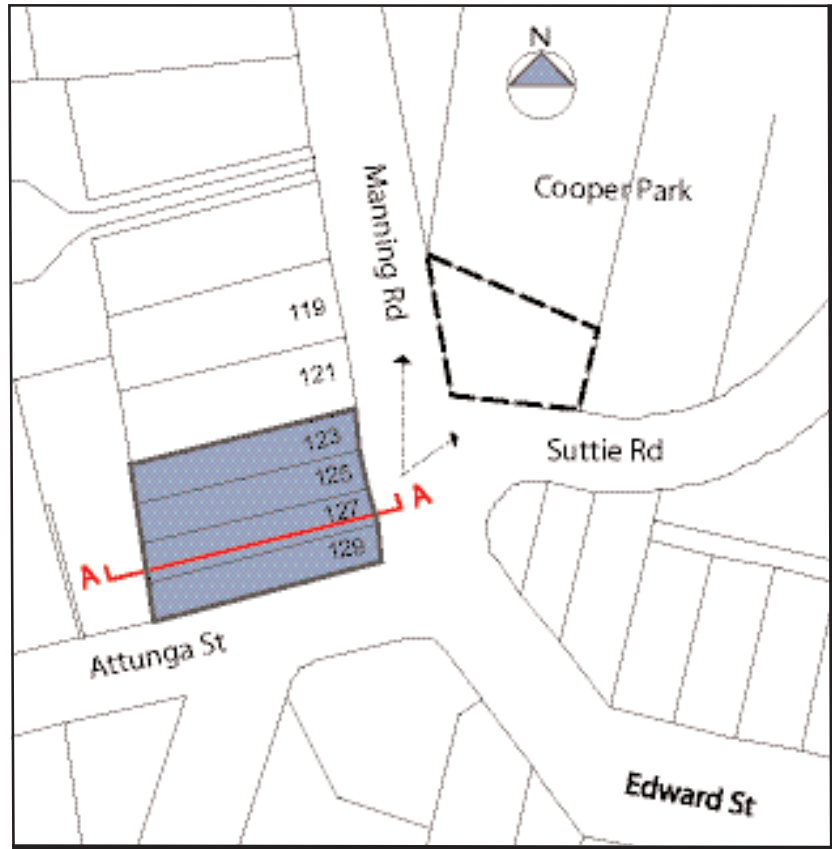

The Manning Road Centre is located at the lower end of the Cooper Park Gully at the junction of Manning Road and Edward Street. It is a very small centre situated about midway between Double Bay and the Edgecliff Road centre, which offers both local and more specialised services.

Historical Development

Edgecliff Road was formed in 1844 as the eastern boundary of the Cooper Estate that skirted around the top of the slopes of the Double Bay valley. The Harbour View Estate was released in 1900 and extends from Edgecliff Road down to the lower end of Cooper Park dedicated in 1919). Later Inter-war subdivision of land along Manning Road followed introduction of the tram on Edgecliff Road in 1909.

Built Form

The small group of commercial and retail premises occupy two substantial two-storey residential buildings that have been modified by the addition of awnings and hard pavement to the front setback area. South-east of the centre along Edward Street built form is mainly terraces and small cottages on small allotments with little or no front setback. Surrounding development on the flatter land is mainly larger two storey detached houses and a few small residential flat blocks of three-four storeys, all set in established treed gardens.

Heritage and Contributory Buildings

Cooper Park Garage at the corner of Sutie Road and Manning Road – single storey stone-block shed located within the public reserve.

Public Parks and Community Facilities

The Neighbourhood Centre overlooks sporting fields and treed slopes in the filled gully of Cooper Park.

Public Domain

The centre has reasonable pedestrian amenity with deep awnings, small street trees and a wide paved setback area for *al fresco* uses. The resolution of pavement levels and accessibility from the street is generally poor. Pedestrian movement to and from Cooper Park is compromised by speed of vehicular traffic and limited sightlines.

Access and Circulation

The centre is served by buses running along Manning Road, although most shoppers are reliant on car transport and the turnover of on-street car parking spaces.

Views and Aspect

The centre faces east to Cooper Park.

**MANNING ROAD
WOOLLAHRA****Manning Road and
Attunga Street**

MANNING ROAD

WOOLLAHRA

Desired Future Character Objectives – Manning Road Neighbourhood Centre

- O 4.10.1** To support local retail and specialty services.
- O 4.10.2** To retain the setback areas on Manning Rd for *al fresco* trading and public use.
- O 4.10.3** To support the evolution of building styles through the introduction of well designed contemporary buildings.
- O 4.10.4** To improve the amenity of pedestrian and *al fresco* trading areas.
- O 4.10.5** To protect views from the centre to Cooper Park.
- O 4.10.6** To improve the pedestrian connection between the centre and Cooper Park.

Desired Future Character Performance Criteria – Manning Road Neighbourhood Centre

- C 4.10.1** Development is a maximum of three storeys.
- C 4.10.2** Development retains the setback area from the Manning Road boundary.
- C 4.10.3** Development **does not** include a retail frontage that exceeds an existing lot width.
- C 4.10.4** Development **does not** include vehicular access from Manning Road.
- C 4.10.5** Development maintains the views and vista corridors shown on the Precinct Map.
- C 4.10.6** Development includes street tree planting and streetscape improvements.

**MANNING ROAD
WOOLLAHRA**

Manning Road Section

Development conforms to the requirements detailed in the annotated street section below, that indicates the existing street context and illustrates the desired future character for the centre.

C 4.10.7 STREET LANDSCAPE

Development includes advanced tree planting and landscape works to improve amenity of setback area.

C 4.10.8 FRONT SETBACK

All development is setback from the street boundary as shown.

C 4.10.9 STREET AWNING

Development includes a continuous solid suspended awning over the setback area (see Part 5).

C 4.10.10 BUILDING ARTICULATION

Building articulation is in the form of projecting balconies over the awning or recessed balconies and loggia within the building mass.

C 4.10.11 OCCUPIABLE AREA

Development uses a maximum of 50% of the potential building envelope as occupiable area.

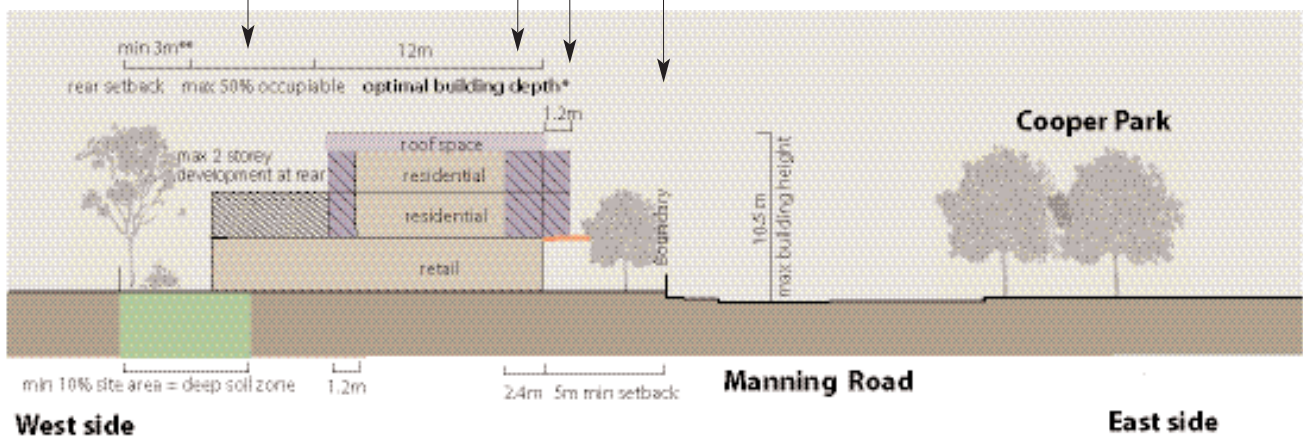

* Refer to Part 5.3.2

** Refer to Part 5.3.18

The maximum height of development in metres is determined by the height controls in Woollahra LEP 1995.

4.11
DARLING POINT
ROAD

Figure 4.11.1
DARLING POINT
PRECINCT MAP

LEGEND

-  Extent of Neighbourhood Centres DCP
-  Neighbourhood business zone 3(c)
-  Significant views and vistas
-  Street section

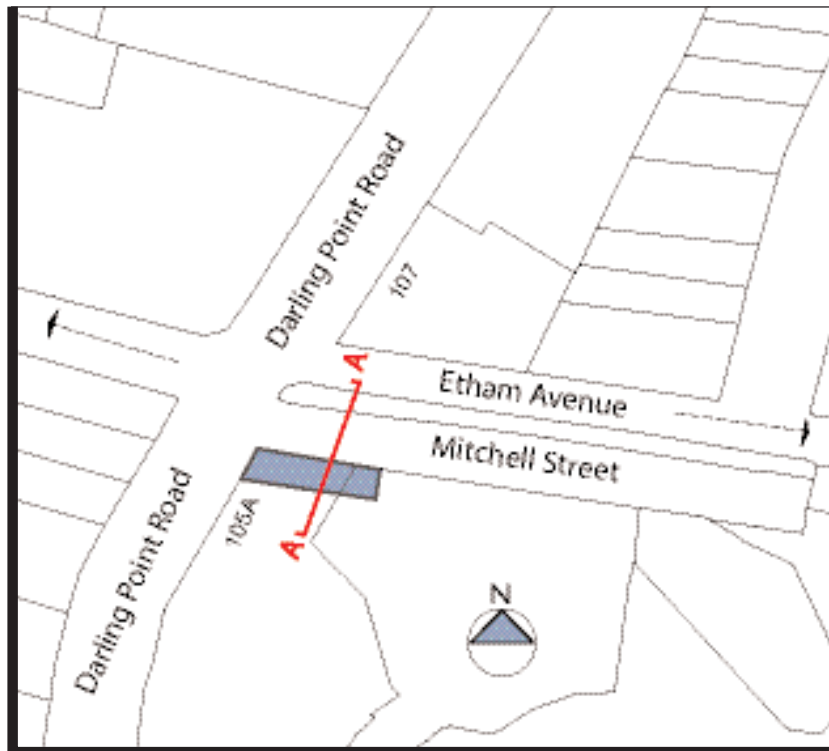

The local shops are located on the northern sections of Darling Point Road; the main thoroughfare since the layout of Mrs Darling’s Point in 1833, that winds along the ridge towards the harbour. The site on the corner of Mitchell Road is part of the perimeter to the former Babworth House Estate. The gardens and tree canopy immediately behind the centre permit an understanding of the site’s history. It is a very small centre which offers local services.

Historical Development

Significant subdivision of Darling Point occurred in the early 1830s with a number of large estates established at that time. Its position and aspect ensured that the rich and powerful reserved this small promontory for their grand residences. By the end of the century, however, smaller residences were also numerous and during the twentieth century development intensified as more and more allotments were subdivided from the grounds of the great houses and gentleman’s villas. The Etham Estate (1900) was one such subdivision located close to the centre. During the second half of the twentieth century, a number of high rise units were built throughout Darling Point. The neighbourhood centre was constructed during this period.

Built Form

This group of shops is housed within a single storey flat roofed building. It is built to the street alignment with a small canvas awning. Within the immediate environs of the centre and within the grounds of the former Babworth House Estate are high rise apartment blocks. Also within close proximity of the centre on Darling Point Road are grand 19th century two storey dwelling houses and terraces.

Heritage and Contributory Buildings

The sandstone, brick and iron fencing and gateposts in Darling Point Road and Mitchell Road were formerly part of Babworth House and are listed as a heritage item in Woollahra LEP 1995. Cleveland at 56 Darling Point Road is immediately opposite the centre and the house and gardens are also listed as heritage items.

Public Domain

The centre has reasonable pedestrian amenity with a northerly aspect and a wide paved area for *al fresco* uses. Mature street trees in Darling Point Road and nearby gardens provide the centre with a leafy ambience. Amenity would be improved with the introduction of street trees within the footpath outside the centre.

Access and Circulation

The centre is served by buses running along Darling Point Road, although the centre is accessed primarily by foot or car transport.

Views and Aspect

There is a west facing view of the harbour down Goomerah Crescent.

Desired Future Character Objectives - Darling Point Road

- O 4.10.1** To support local retail services.
- O 4.10.2** To retain views to the leafy backdrop provided by the the gardens of the former Babworth Estate.
- O 4.10.3** To support the evolution of building styles through the introduction of a well designed contemporary building.
- O 4.10.4** To improve the amenity of the pedestrian and *al fresco* trading area.
- O 4.10.5** To protect views from the public spaces within the centre to the harbour.

DARLING POINT ROAD

Mitchell Street at Darling Point Road

**DARLING POINT
ROAD****Desired Future Character Performance Criteria - Darling Point Road**

- C 4.11.1** Development is a maximum of one storey.
- C 4.11.2** Development provides buildings of consistent scale and form, with an articulated roof form
- C 4.11.3** Development **does not** include vehicular access from Mitchell Street.
- C 4.11.4** Development permits an interpretation of the perimeter walling to Babworth House.
- C 4.11.5** Development maintains views of the garden of the former Babworth Estate when viewed from Darling Point Road.
- C 4.11.6** Development maintains the views and vista corridors shown on the precinct map.
- C 4.11.7** Development includes street tree planting and streetscape improvements.

DARLING POINT ROAD

Darling Point - Mitchell Street Section

Development conforms to the requirements detailed in the annotated street section below, that indicates the existing street context and illustrates the desired future character for the centre.

C 4.11.8 STREET LANDSCAPE

Development includes advanced broad canopy tree planting in the footpath to provide shade and shelter.

C 4.11.9 STREET AWNINGS

Development includes all weather protection to shop entrances.

C 4.11.10 ROOF FORM

Development provides an articulated roof form.

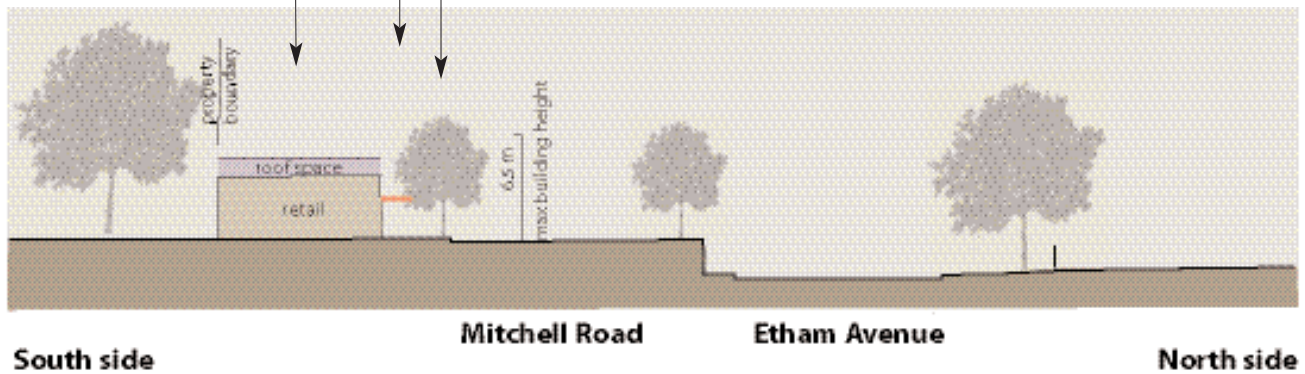

The maximum height of development in metres is determined by the height controls in Woollahra LEP 1995.

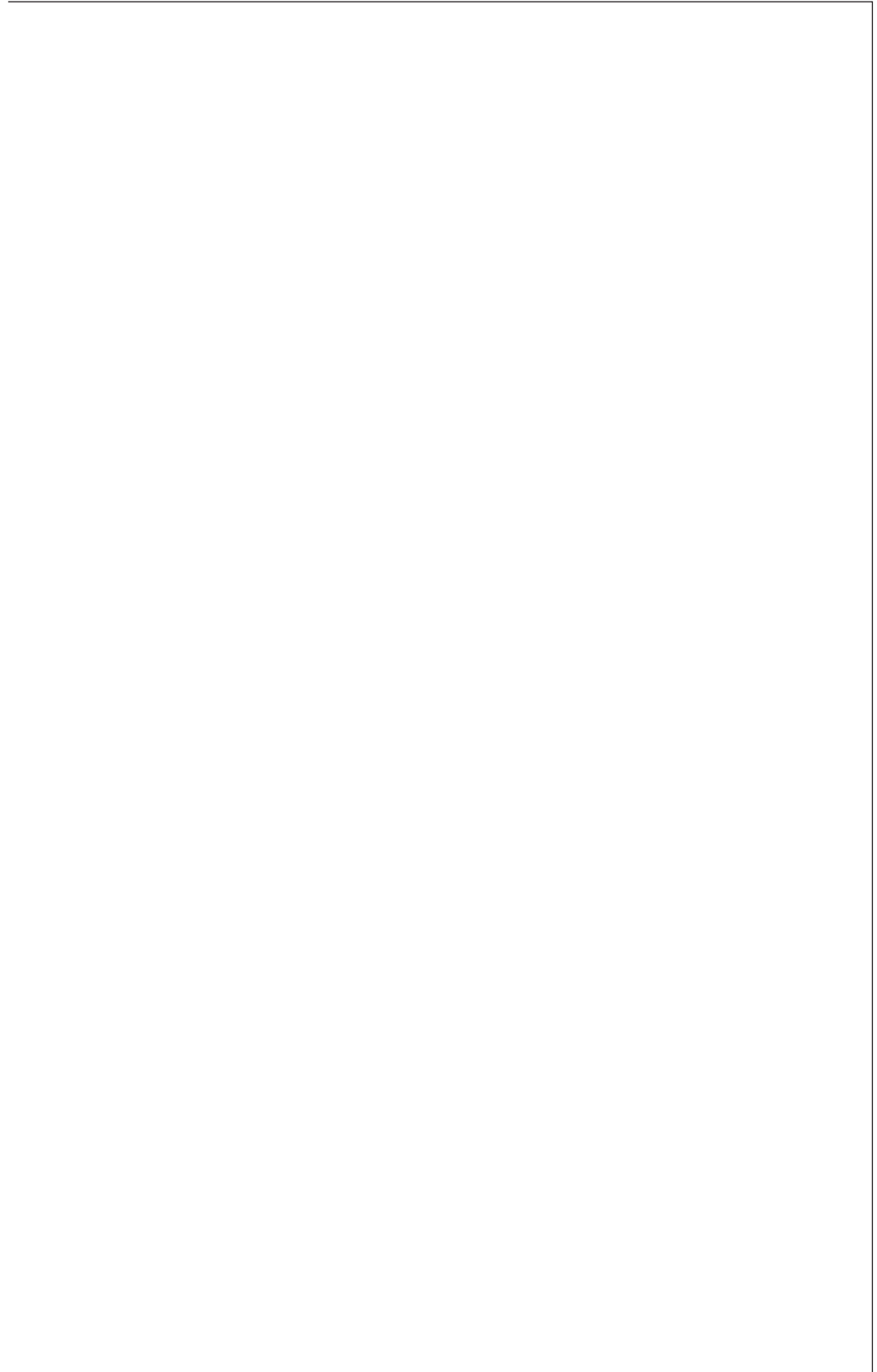

PART

5

General controls

PART 5

Introduction

General controls apply to all sites regardless of the precinct in which they are located. The general controls are divided into fifteen clauses. Developments are required to fulfil the relevant requirements of all general controls.

The general controls in Part 5 comprise three basic elements:

- an explanation of the topic;
- a set of objectives; and
- performance criteria.

The explanation for each topic provides background information on why the topic is important and how it is relevant to building design. The explanation will help to determine in what ways the general controls should be applied to development. The objectives for each topic describe the outcomes that proposed developments are required to achieve. In order to gain Council approval, developments need to demonstrate that they have fulfilled the relevant objectives for each topic.

The performance criteria represent specific ways in which a development proposal can meet the objectives for the topic. Development proposals are required to address all relevant performance criteria. The intent of the performance criteria must be interpreted in the context of the topic's objectives.

5.1 USES

Explanation

The neighbourhood centres generally consist of a mix of small scale shops and commercial premises at street level with some residential dwellings above. Centres with continuous ground level retail frontage offers the benefits of safety, commercial activity and street life, whilst the provision of housing on the upper levels can make a significant contribution to the local character, provide street surveillance and contribute to after hours activity in the centres.

Objectives

- O 5.1.1** To promote a mix of residential and non-residential land uses that helps preserve the commercial viability of neighbourhood shopping centres, that is consistent with the availability of local services and public transport.
- O 5.1.2** To maintain continuous retail or commercial uses at street level in each centre.
- O 5.1.3** To preserve the small shop character of each centre.
- O 5.1.4** To encourage activities that achieve an appropriate level of environmental performance, such as acceptable noise levels.
- O 5.1.5** To encourage redevelopment of identified key sites.
- O 5.1.6** To improve the quality, safety and amenity of the pedestrian environment.

Performance criteria

- C 5.1.1** Residential uses are prohibited on the ground floor with the exception of access areas for residential uses on upper levels.
- C 5.1.2** Buildings are designed for commercial or retail uses only at ground level.
- C 5.1.3** Floors two levels and greater above the retail street level are to be designed for residential use only.
- C 5.1.4** Buildings and spaces are designed to be durable and adaptable.
- C 5.1.5** The retail frontage at street level for individual retail units matches the traditional subdivision pattern.
- C 5.1.6** Retail premises of less than 200m² have a depth to width ratio between 1:1 and 3:1.

Explanation

Streetscape quality helps to provide local amenity and identity. Safeguards are needed to ensure that the streetscape qualities of new development are compatible with the desired future character of the centre. New development should recognise predominant streetscape patterns, such as building form, roof design, front setbacks, awnings and predominant materials to ensure a cohesive streetscape character.

The creation of attractive and lively street environments can help to slow traffic, foster the use of streets as places for social interaction and encourage pedestrian and cyclist activity.

Objectives

- 0 5.2.1** To ensure development contributes to cohesive streetscapes and desirable pedestrian environments.
- 0 5.2.2** To ensure development conserves or enhances items and areas of special architectural, social, cultural or historic interest.
- 0 5.2.3** To ensure a safe environment by promoting crime prevention through design.
- 0 5.2.4** To ensure development responds to predominant streetscape qualities.
- 0 5.2.5** To create an active interface between ground level retail or commercial properties and the street.



**Upper level entry, South
Head Roundabout**

Performance criteria

- C 5.2.1** Buildings are located as close to the street alignment as possible to promote interaction between pedestrians and shopfronts.
- C 5.2.2** Development on a site that exceeds the traditional lot size and that has a sloping frontage is designed to step with the longitudinal grade of the street.
- C 5.2.3** Development continues the predominant built form character of the street, including parapet lines, floor to ceiling heights and roof pitches.
- C 5.2.4** Development maintains the predominant balance of horizontal and vertical proportions in the street.
- C 5.2.5** Development includes display windows with clear glazing to ground floor retail and commercial premises, with a maximum window sill height is 0.7m.
- C 5.2.6** Each building has a clear street address where entries to upper level development are well defined at the street frontage.
- C 5.2.7** Access to upper level uses does not occupy more than 20% of the ground floor frontage.
- C 5.2.8** Development to re-use existing buildings reinstates missing façade elements and decorative details.
- C 5.2.9** The street facade design uses materials which are compatible with the existing development context.
- C 5.2.10** Vehicular entries are discrete and minimise conflicts with pedestrians.
- C 5.2.11** Security features at ground level complement the design of the facade and allow window shopping and the spill of light into the street out of business hours.
- C 5.2.12** Buildings design provides windows that overlook the street on all street frontages.
- C 5.2.13** Building design avoids dead edges at ground floor level, such as car parking frontages, blank walls and recessed spaces.

Awnings

- C 5.2.13** Development provides awnings as indicated in Part 4 of this DCP.
- C 5.2.14** Awning design is a solid suspended steel box type section, with a minimum soffit height of 3.2 metres. Awning height provides continuity with adjoining properties, follows the street grade, and is of sufficient depth to provide good shade and shelter to pedestrians.
- C 5.2.15** Under awning lighting is included; either recessed into the soffit of the awning or wall mounted on the building.

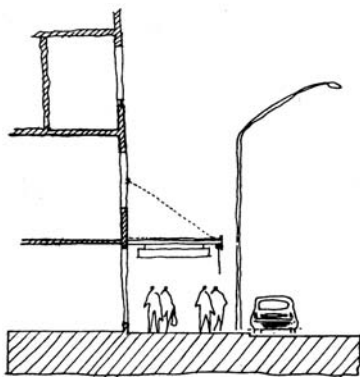

Fig 5.1
Awning design

**Suspended steel box section type
with a minimum soffit height of
3.2 metres.**

5.3 BUILT FORM

Explanation

Controls for building size and location are contained in Woollahra LEP 1995 and this NC DCP. Woollahra LEP 1995 includes floor space ratios and height controls. This NC DCP contains front, side and rear setback controls.

The maximum permissible floor space ratios as set down in Woollahra LEP 1995 are not “as of right”. To achieve the maximum permissible floor space ratios a development must satisfy all relevant controls applicable to the land. It is intended that the gross floor area of a development be fully contained within the building envelope created by the maximum building height in metres specified in Woollahra LEP 1995 and the controls for building footprint, building height in storeys, and front, side and rear setbacks specified in this NC DCP. The permissible gross floor area for each site is generally 80% of the theoretical floor space achievable within the building envelope.

The desired built form for each of the centres is illustrated in the precinct street sections (Part 4). Buildings in the centres are generally row buildings with the massing concentrated to the street frontage. Typically they are built from side boundary to side boundary along the street frontage, clearly defining the edges of the street. In many centres strong corner buildings provide termination to the row and emphasise the corner. The centres are characterised by a predominance of articulated parapets and hipped roof forms that contribute to their urban character.

At the rear of neighbourhood centre sites the built form is generally less bulky and provides a transition to residential sites. The controls for maximum **occupiable area** limit building massing to the rear of properties (‘50% occupiable area’ means that no more than half of the maximum possible floor plate on each level is to be occupied by floor and non-floor space elements). This allows for design flexibility in order to address amenity issues for both existing and new dwellings.

The built form controls provide for a mix of uses in the centre. The deep ground level floorplates are suitable for retail and commercial uses, whilst the depth of upper level floorplates is suitable for residential uses. The depth of the residential component of buildings promoted in this NC DCP provides for natural lighting and ventilation.

Car parking above ground is not encouraged. The inclusion of car parking at or above ground level will not warrant an increase in the size of the building envelope, and such a development may not achieve its permissible floor space.

Objectives

- O 5.3.1** To achieve a built form of a scale and character in keeping with the desired future character of each centre.

- O 5.3.2** To relate new development to existing boundary lines and grades along the street frontage.
- O 5.3.3** To encourage building massing and articulation that creates strong corner buildings.
- O 5.3.4** To promote building forms that provide quality internal environments and allow natural day lighting, natural ventilation and visual and aural privacy between dwellings.
- O 5.3.5** To protect good solar access to the public domain in winter.
- O 5.3.6** To encourage roof design that creates a distinctive silhouette to buildings.

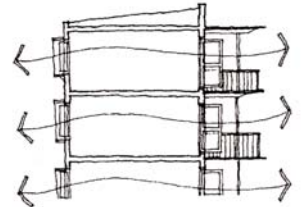

Fig 5.2
Cross ventilation

Thin cross-section design achieves good cross ventilation and assists day lighting of rooms.

Performance criteria

Building envelope

- C 5.3.1** Development is proposed in accordance with the precinct section drawings in Part 4.
- C 5.3.2** Development for residential housing provides an optimal building depth of 10-14m, including the articulation zones, or where building depth exceeds 18.0 m, the applicant has demonstrated how satisfactory daylighting and natural ventilation is achieved.
- C 5.3.3** Development includes courtyards and light wells at ground and first floor level of deep blocks to provide natural lighting and ventilation.
- C 5.3.4** The building footprint is designed to minimise cut and fill.
- C 5.3.5** Development provides a range of residential accommodation types and forms (such as multi-level dwellings on the upperstoreys).

Height

- C 5.3.6** Buildings achieve, but do not exceed, the heights along the primary street frontages described by the street sections in Part 4.
- C 5.3.7** The floor to ceiling height of ground floor development is at least 3.3m to allow flexibility for changes in tenancy
- C 5.3.8** Habitable rooms in residential apartments achieve a minimum floor to ceiling height of 2.7m.

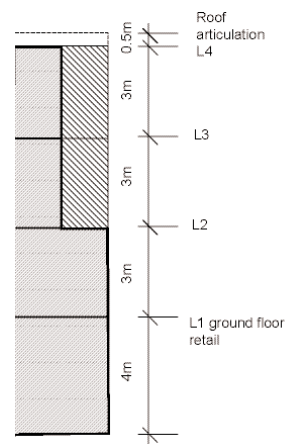

Fig 5.3
Maximum building height

Has been calculated from storey heights indicated. "4" represents 4 storeys and 13.5m maximum building height. Applicants may chose to vary storey height using 3.5m height for ground floor (L1) and (L2), create double storey spaces of 7m and the like.

- C 5.3.9** Development does not exceed a maximum wall height along rear lanes of 7.2m.
- C 5.3.10** The height of rear and side walls take account of potential overshadowing to adjoining properties.
- C 5.3.11** To allow resolution of the roof form, the floor level of the uppermost habitable storey is 3.5m or more below the maximum permissible building height.
- C 5.3.12** The building form (including parapet, lift tower, machinery plant rooms and storage space) is contained within the envelope height.
- C 5.3.13** Chimneys, stacks, vent pipes, and television antennae exceeding the building envelope height are not readily visible from the public domain.

Setbacks

- C 5.3.14** Development complies with front setbacks as illustrated in section drawings in Part 4.
- C 5.3.15** Front setbacks define a coherent alignment to the public domain and accentuate street corners.
- C 5.3.16** Side setbacks protect privacy to adjoining buildings; and allow access to natural light and ventilation.
- C 5.3.17** Rear setbacks accommodate vehicle access to the rear of lots (where required) and provide deep soil landscape zones (where blocks adjoin residential areas) or public open space).
- C 5.3.18** For development on a site immediately adjoining an allotment zoned residential or public open space, the development provides:
- a minimum rear setback of 3.0m, increasing on a pro-rata basis by 0.5m for each metre the wall height adjacent to the boundary exceeds 3.0m and
 - a minimum side setback of 1.5m where the side boundary immediately adjoins the residential zoned allotment.
- C 5.3.19** For development on a site with rear lanes access and a lot depth of 40m or greater, development facing the rear lane is built to the boundary.

C 5.3.20 Where there is no rear lane access, development provides a minimum 1.0m side access to the rear of properties .

C 5.3.21 Where an upper level setback is required, that setback alignment is parallel to the street boundary alignment.

C 5.3.22 Primary door and window openings in residential living areas are located towards the street and/or rear lane and protect privacy. Living areas with primary openings that face a side boundary are avoided.

Corner buildings

C 5.3.23 The design of corner buildings reflects the street geometry, topography, sight lines and skyline elements.

C 5.3.24 Street corners are strengthened by massing and building articulation to both frontages

C 5.3.25 Development on a corner site achieves the maximum prescribed height to both frontages.

C 5.3.26 Development on a corner site that is identified in Part 4 of this NC DCP, and that complies with the development controls, may be granted up to 0.5:1 additional FSR.

Roof Design

C 5.3.27 The profile and silhouette of parapets, eaves and roof top elements is integrated in roof design.

C 5.3.28 Where pitched roofs are proposed, the angle of the pitch is compatible with the existing development context.

Roof Terraces

C 5.3.29 Where a roof terrace is proposed, it adjoins habitable space that is on the same floor level. Development must not include a rooftop terrace that is only accessed from a stairway and/or lift.

C 5.3.30 Where a lightweight pergola, sunscreen, privacy screen or planter is proposed, it does not increase the bulk or exceed the permissible maximum height of the building, or significantly affect the views available from adjoining properties, from the immediate vicinity or from nearby ridges.



Fig 5.4
Strong corner building -
Plumer and O'Sullivan
Roads

5.4
BUILDING
ARTICULATION



Fig 5.5
Recessed balcony



Fig 5.6
Part projecting balcony

Explanation

Building articulation refers to the three dimensional modelling of a building façade. Building articulation along the street frontage establishes the relationship between a building and the street, through the use of elements like wall offsets, entry porches, loggias, balconies and bay windows. Traditionally, buildings in the neighbourhood centres are built to the street alignment with recessed balconies on the upper levels.

Articulation zones allow for the design of accessible and comfortable private outdoor living areas, which is a major determinant of the ability of occupants to enjoy living in the centres.

The section drawings in Part 4 indicate the area for building articulation.

Objectives

- O 5.4.1 To create a strong street address and enrich the character of the centre through appropriate building articulation.
- O 5.4.2 To ensure every dwelling has direct access to private open space.

Performance criteria

- C 5.4.1 Building articulation is provided as indicated in the precinct section drawings of Part 4 of this NC DCP
- C 5.4.2 Building articulation responds to environmental conditions such as orientation, noise, breezes, privacy and views.
- C 5.4.3 Architectural detailing or balconies project no more than 500mm beyond the preferred building line.
- C 5.4.4 Between 20% and 80% of the building articulation area as shown on the control drawings is occupied by floor area elements (which are included in the floor space calculations).
- C 5.4.5 The following **floor area elements** only are used within the area for building articulation:
 - Habitable rooms
 - Entries
 - Bay windows
 - Glazed balcony enclosures

The following **external articulation elements** only are used within the area for building articulation:

- Balconies
- Terraces
- Verandahs
- Loggias
- Decks
- Porches
- External access stairs
- Solar protection elements such as roof overhangs, external louvred walls, screens, awnings and deep reveals.
- Decorative architectural elements such as corbelling, projecting sills and expressed window openings.

C 5.4.6 Blank party walls are avoided, and some modelling is provided to party walls.

C 5.4.7 Facades are richly articulated and express the different levels of the building and/or its functions.

Above ground private open space

C 5.4.8 Development provides at least one balcony, terrace, verandah, loggia, roof terrace or deck for each dwelling within the area nominated for building articulation or within the area nominated '50% occupiable'. This open space is accessible from a principal living area.

C 5.4.9 The preferred depth of the required open space is 2.4m and the minimum permissible depth is 1.8m. The minimum area of private open space is determined by the dwelling size and is outlined below.

small dwelling	less than 60m ²	8m ²
medium dwelling	60-80m ²	12m ²
large dwelling	more than 90m ²	16m ²

5.5
HERITAGE AND
CONTRIBUTORY
BUILDINGS



Fig 5.7
98B Bellevue Road at
Streatfield Centre

Explanation

Woollahra Council supports the conservation of the rich mixture of buildings and places of special significance within the municipality. Woollahra LEP 1995 contains controls on the conservation of items and areas of heritage significance.

Council also wishes to promote historic continuity to maintain the local identity of the neighbourhood centres. Part 4 (Precinct controls) identifies heritage and contributory buildings. These are buildings that are in some way notable; they are of architectural merit, or belong to a group of buildings that together define a street corner, or are well built using quality materials, or have distinguished features that remain substantially intact.

Where a development involves a heritage item or contributory building, Council requires that a statement of heritage impact be lodged with a development application.

Objectives

- O 5.5.1** To protect and enhance items of heritage significance, including contributory buildings.
- O 5.5.2** To ensure that identified contributory buildings are retained and adaptively reused.
- O 5.5.3** To support new building design that responds to and complements the form and character of heritage and contributory buildings.

Performance criteria

- C 5.5.1** Proposed development involving a heritage item complies with the heritage provisions of Woollahra LEP 1995.
- C 5.5.2** The heritage significance of the heritage or contributory building is not compromised by the proposed development.
- C 5.5.3** New development adjacent to heritage and contributory buildings is sympathetic in scale, alignment, detailing and materials.

- C 5.5.4** An application to upgrade or re-use a contributory building, must clearly demonstrates that the architectural and streetscape value of the building would be retained or enhanced by the proposal.
- C 5.5.5** The demolition of contributory buildings as identified in part 4 of this DCP is discouraged. An application to demolish a contributory building must clearly demonstrate that development would provide a replacement building of higher quality (than the contributory building) with respect to streetscape character, architectural design, internal and external amenity, flexibility of uses, material quality and construction.

5.6

ENERGY AND

WATER EFFICIENCY

Explanation

Energy and water efficiency provisions aim to promote ecologically sustainable development (ESD) by minimising green house gas emissions, reducing the consumption of non-renewable resources and the demand for reticulated water resulting from mixed use development. Energy and water efficiency can also lead to significant cost savings for occupants.

Below is a list of design considerations for maximising energy efficiency. This is not a definitive list and should be read in conjunction with other accredited information including the provisions under BASIX and the current Building Code of Australia.

Orientation

The orientation of living areas relative to the sun's movement can significantly influence amenity, internal temperatures and demand for heating appliances. Living areas should be orientated towards the north for maximum solar access.

Lighting

The building should be designed so that artificial light in dwellings is unnecessary during daylight hours, and use of energy efficient lamps and fittings, requiring less than 3 watts/m² of installed lighting.

Space heating and cooling and ventilation

The selection of an energy efficient heating/cooling system should be made during the development design stage and should target only those spaces which require heating or cooling and ensure the efficient distribution/re-distribution of air. Where a space heating and cooling system is installed, it should be selected for maximum energy efficiency.

Harnessing cooling breezes and natural ventilation is important during warmer months. Maximum air movement can be obtained by locating smaller openings low on the windward side and large openings high on the leeward side. The size and location of windows can also influence cross-ventilation.

Building Fabric and Thermal mass

Heavyweight building materials, such as concrete slab floors, cavity brick, concrete blocks, stone walls, mud brick and rammed earth, absorb heat during the day and release it at night, resulting in cooler indoor conditions during the day and warmer conditions at night.

To be most effective, materials with thermal mass should be located inside the insulated fabric of the dwelling in north facing rooms.

Glazing

Glazing in north-facing rooms maximises solar penetration to dwellings during cooler months. Glazing with a southerly aspect should generally be kept to a minimum, keeping in mind requirements for cross-ventilation and natural light. It is preferable to minimise

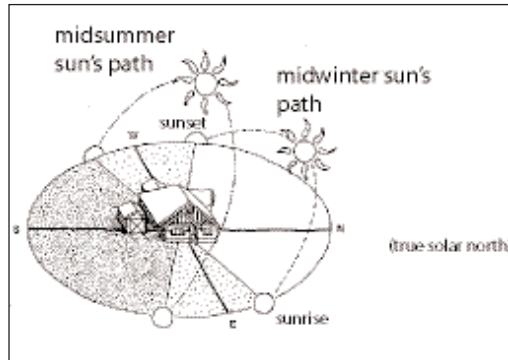

Fig 5.8
Differences in the sun's apparent movement throughout the year need to be considered in the location and design of windows, living areas, landscaping and shade devices.

glazing to the east and west of a building where the sun will be at its lowest angle and where it is difficult to prevent heat intake during warmer months. Where buildings have major glazing areas facing between 110° east and 110° west of north, they should be designed to be energy efficient (ie: low emissivity or double glazed).

Shading and Landscaping

Wide canopied deciduous trees and deciduous vines grown on pergolas to the north of dwellings will provide shade during warmer months and allow sunlight penetration during cooler months. As many deciduous species can block sun during early autumn and late spring, the use of eaves to control sun penetration is desirable. Where practicable evergreen trees can be used to the west and east of habitable areas to prevent glare and heat during warmer months. Landscaping can also be used to screen prevailing winds, deflect cooling summer breezes into dwellings, provide cooling air through leaf transpiration, reduce glare and modify temperatures throughout the year.

Insulation and Building Sealing

Insulation and weather sealing are the most important determinants of heat loss and gain. Generally, bulk and reflective foil laminate insulation of the roof and walls would be required.

Appliances

Considerable energy savings can be achieved through the choice, location and use of services, lighting and appliances within dwellings. The most intensive appliances are those used for heating and cooling the dwelling during winter and summer. Appliances with maximum energy efficiency should be installed, preferably labelled with 'Energy Smart' logos, including appliances such as: white goods, showerheads, light bulbs, water heaters and insulation.

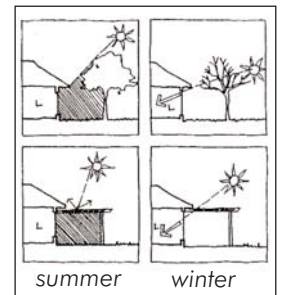
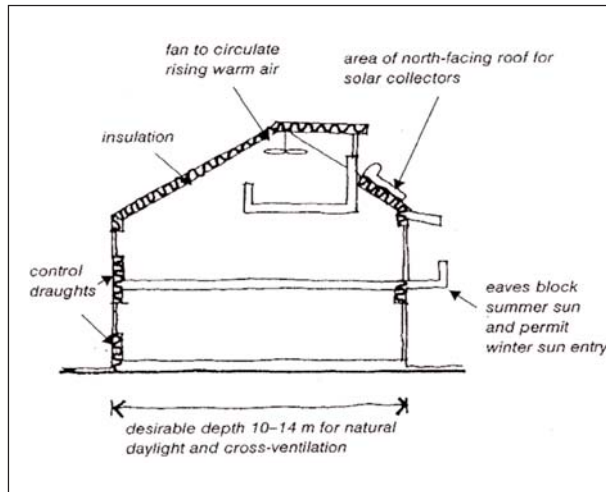

Figure 5.9
Appropriate planting used to control sun exposure.

Water Demand

Fig 5.10
Some considerations for energy efficient housing



Objectives

- 0 5.6.1** To minimise fuel use and greenhouse gas emissions through the promotion of energy efficiency in the design, construction and use of housing.
- 0 5.6.2** To maximise the benefits of passive solar design.
- 0 5.6.3** To improve the energy efficiency of buildings.
- 0 5.6.4** To reduce the necessity for mechanical heating and cooling.
- 0 5.6.5** To promote the installation of greenhouse-friendly hot water systems and other energy efficient appliances.
- 0 5.6.6** To maximise the use of natural light and minimise energy use for internal lighting.

Performance criteria**Retail and commercial development**

- C 5.6.1** Development for a new commercial building complies with the principles of the BASIX (the Building Sustainability Index) planning tool.
- C 5.6.2** A satisfactory report on energy and water efficiency is submitted with the development application for any building works with a construction cost of \$500,000 or more.
- C 5.6.3** Any required report on energy efficiency includes a satisfactory review of:
- building or design elements that may require modification to address the efficiency requirements of the current BCA
 - Re-use of existing buildings or building design capable of adaptation in the long term.
 - Passive solar design principles used to avoid the need for additional heating and cooling.
 - Substitution of non-renewable fuels for renewable fuels such as solar hot water heating.
 - Use of recycled and/or low embodied energy building materials.
 - Use of building articulation (courtyards and light wells) that allow daylight into ground and first floor levels.
 - Location of skylights to ensure that they **do not** provide the sole source of daylight and ventilation to habitable rooms
- C 5.6.4** Building design incorporates water conservation devices with a “AAA” Australian Standards Water Conservation Rating , including tap flow regulators, shower head roses and dual flush toilets.

Residential component of development

- C 5.6.5** A satisfactory BASIX Certificate is submitted with the development application for the residential component of a mixed use development, including major alterations and additions to residential development.

Note: BASIX is the environmental standard that must be attained to reduce water consumption and energy emissions. To obtain a certificate, applicants must complete an on-line assessment using the BASIX tool. Details are at www.basix.nsw.gov.au

Solar Access

C 5.6.6 Where already existing, access to sunlight is maintained for a minimum period of three hours between 9.00am and 3.00pm on June 22 to the north facing windows of habitable rooms and private open space of adjoining properties. Where existing overshadowing is greater than this, access to sunlight is not further reduced by new development.

C 5.6.7 Access to sunlight is provided for a minimum of three hours between 9.00am and 3.00pm on 22 June to north-facing windows of habitable rooms and private open space of the new development.

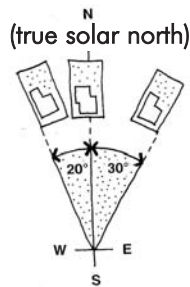

Fig 5.11
"North-facing" refers to rooms and open space areas located on the northern side of buildings as shown. These areas are likely to benefit most from solar access.

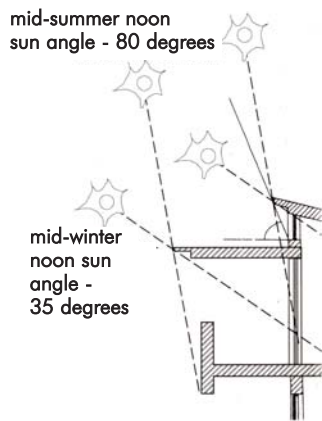

Fig 5.12
Mid-winter and mid-summer solar angles for openings facing true north

The design of north facing balconies and rooms should aim to admit low angle winter sunlight, and exclude high angle summer sunlight

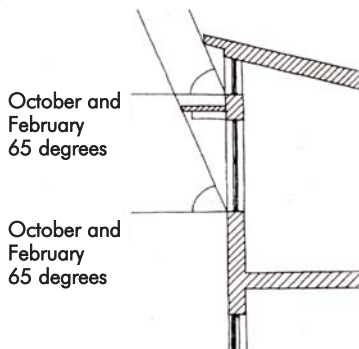

Fig 5.13
Solar angles for windows facing true north

Source: Energy Information Centre information sheet May 1994

Eaves, screens and the size of openings for north facing balconies and rooms, should be designed with regard to the noon 17 October / 26 February sun angles to maximise winter sunlight penetration, and minimise summer sunlight penetration.

Glazing

C 5.6.12 Areas of glazing are located to avoid energy loss and unwanted energy gain.

C 5.6.13 Development provides appropriate sun protection during summer for glazed areas facing north, west and east. Extensive areas of glazing that are unprotected from sun during summer are not permitted. Shading devices include eaves, awnings, balconies, pergolas, external louvres and projecting sunshades. Unprotected tinted windows are not acceptable.

C 5.6.14 New buildings and facades do not result in glare that causes discomfort or threatens safety of pedestrians or drivers.

C 5.6.15 A Reflectivity Report that analyses potential glare from proposed new development on pedestrians or motorists may be required.

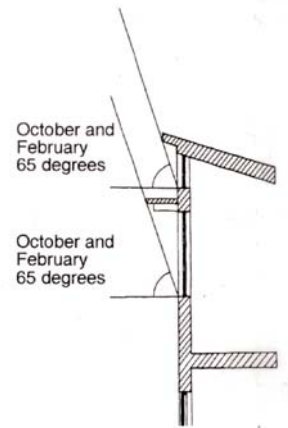

Fig 5.14
Solar angles for north facing windows

To shade glazing in summer

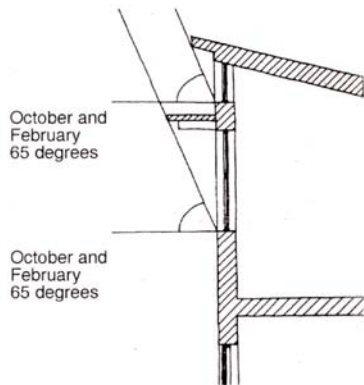

Fig 5.15
Solar angles for fixed louvre pergolas

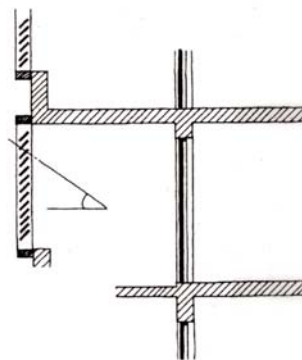

Fig 5.16
Adjustable louvres or sliding

Screens can be used to shade windows to rooms facing east or west

5.7

STORMWATER
MANAGEMENT**Explanation**

Stormwater management is required to protect people and property during floods. Stormwater management is also required to ensure that stormwater does not adversely impact on the quality of natural waterways. 'Stormwater harvesting', where stormwater is saved in rain tanks for garden, washing and toilet flushing, helps to reduce the unnecessary consumption of potable water supplies and the amount of run-off entering the drainage system. Use of stormwater reduces the pressure of new mixed-use development on the mains water supply and infrastructure.

Objectives

- O 5.7.1** To control stormwater quality and quantity, and avoid discharge impacts on adjoining properties and natural waterways.
- O 5.7.2** To maximise the retention and use of stormwater for on-site activities
- O 5.7.3** To reduce the pressure of residential and non-residential development on the potable water supply and stormwater drainage infrastructure.

Performance criteria**Stormwater disposal**

- C 5.7.1** Stormwater controls are designed to:
 - ensure that existing downstream systems are not adversely affected;
 - fit in with the hydrology of the natural system as much as possible;
 - use on-site stormwater retention;
 - take advantage of opportunities for stormwater re-use, such as the use of rainwater tanks;
 - consider the distribution of soil types and the scope for on-site infiltration in areas where this will not contribute to slope instability or ground water pollution;
 - prevent any unexpected rise in ground water level due to development; and
 - retain existing trees and infiltration areas.

Building design for retail and commercial development

C 5.7.2 Building design incorporates the following measures to minimise mains water demand and consumption:

- rainwater tanks to supply water for plant watering, toilet flushing, outdoor cleaning and/or cooling systems for the building
- where suitable, roof gardens to reduce stormwater run-off and provide insulation;
- using an irrigation system that minimises water waste and ensuring that the system responds to the varying water needs of different sections of the garden;
- maximising water retention within gardens by directing run-off from impervious areas and water tanks to deep soil areas.



Fig 5.17
rainwater tanks to supply water for cooling systems,
toilets, outdoor cleaning or gardens

5.8
ACOUSTIC AND
VISUAL PRIVACY

Explanation

Privacy is a major determinant of the ability of residents and neighbours to enjoy their home. Privacy refers to both acoustic and visual privacy. The privacy needs of residents and neighbours should influence all stages of design, from the location of dwellings and the placement of windows and private open space through to the selection of materials and construction techniques. Visual privacy can be achieved by:

- layout that avoids overlooking;
- screening; and
- separation.

The level of acoustic privacy depends upon the location and design of habitable rooms relative to noise sources such as air conditioning units, swimming pool pumps and major roads.

Note: Council may require a Noise Impact Assessment to accompany a DA.

Objective

0 5.8.1 To ensure adequate acoustic and visual privacy for occupants and neighbours.

Fig 5.18
Minimum distances for
visual & acoustic privacy

Source: *AMCORD, 1995*

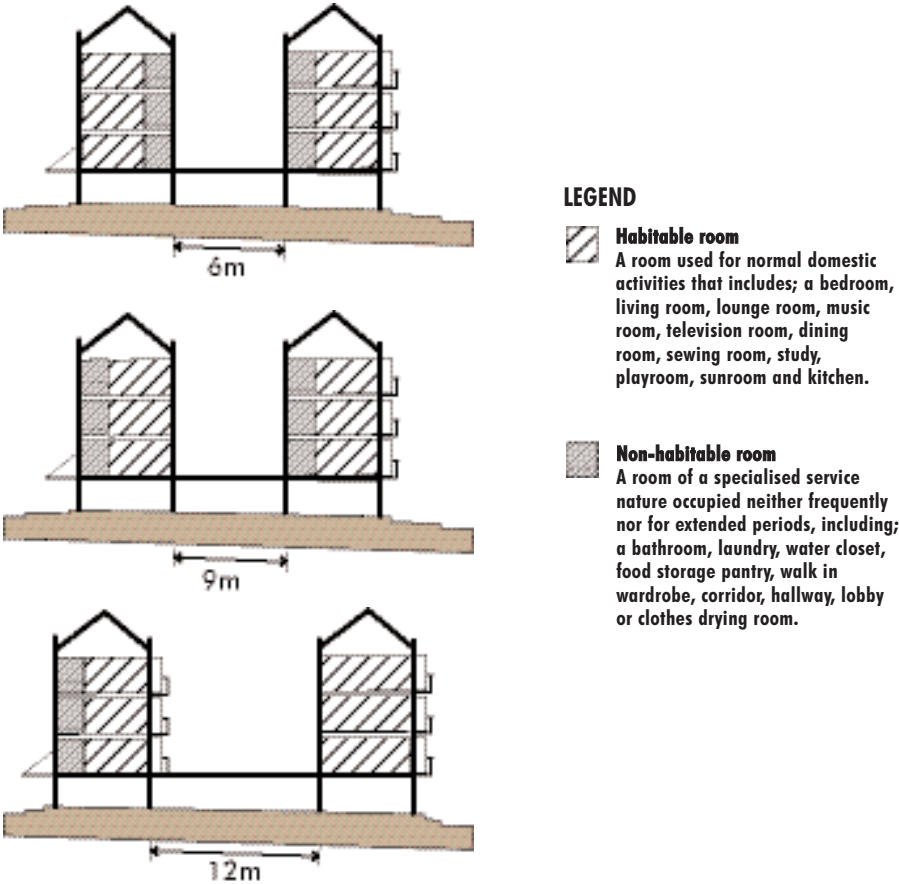

Performance criteria

Acoustic privacy

- C 5.8.1** Buildings are sited to minimise the transmission of external noise to other buildings on the site and on adjacent land.
- C 5.8.2** The internal layout of rooms, courtyards, terraces and balconies, the use of openings, screens and blade walls, and choice of materials, is designed to minimise the transmission of noise externally.
- C 5.8.3** Noise impact associated with goods delivery and garbage collection, particularly early morning is minimised.
- C 5.8.4** Bedroom areas are separated, by way of barriers or distance, from on-site noise sources such as active recreation areas, car parks, vehicle accessways and service equipment areas.
- C 5.8.5** Restaurant development including a cafe is designed to minimise the impact of noise associated with late night operation, on nearby residents.
- C 5.8.6** Rear courtyards would only be permitted for restaurant use if Council is satisfied that the hours of operation would not have an unreasonable impact on residential amenity.
- C 5.8.7** When required by Council, a Noise Impact Assessment is provided to accompany the development application.

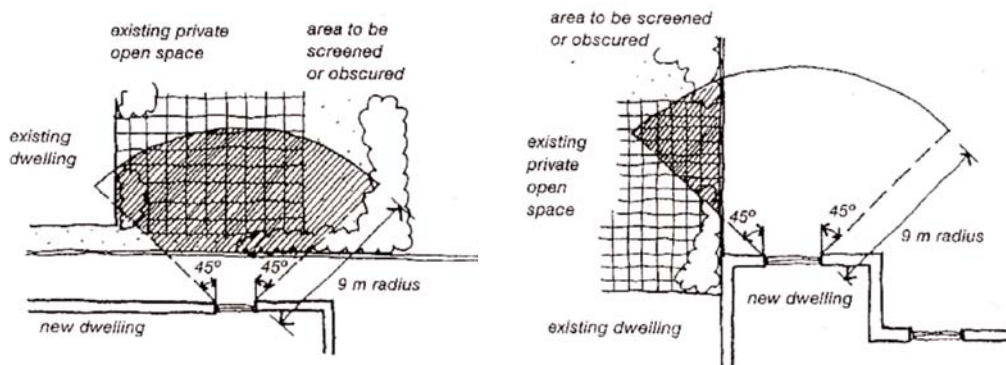

Fig 5.19
Acceptable screening of views to adjacent open spaces.

Visual privacy

- C 5.8.7** Visual privacy is protected by providing adequate distance between opposite windows of neighbouring dwellings where direct view is not restricted by screening or planting.
- C 5.8.8** Windows and balconies of an upper-level dwelling are designed to prevent overlooking of the private open space of a lower level dwelling directly below and within the same development.
- C 5.8.9** Balconies are designed to provide privacy for occupants of the building when viewed from the street or nearby public space.

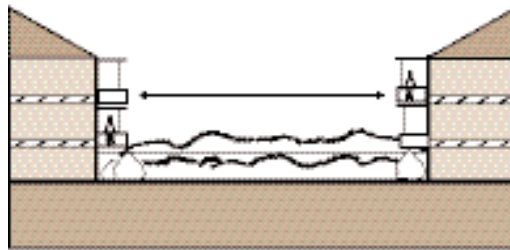

Fig 5.20
Ensure adequate separation between unscreened balconies. Privacy at ground floor level provided by suitable sill heights and planting.



Fig 5.22
Careful location of balconies can increase privacy and reduce their separation.

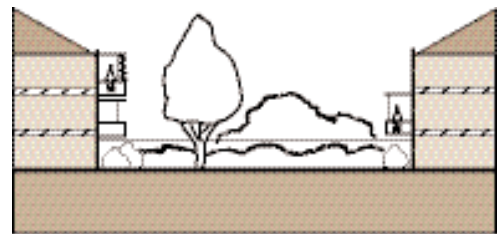

Fig 5.23
Vegetation and balcony screening can increase separation to ensure privacy.

5.9

**CAR PARKING
VEHICULAR ACCESS
AND SERVICING**
Explanation

The neighbourhood centres are located on or close by public transport routes, particularly public buses. Limiting unnecessary car use and encouraging other modes of transport, such as walking, cycling and public transport, helps to improve local amenity and to minimise pollution and the use of non-renewable energy sources. Council's carparking requirements aim to satisfy the parking demand likely to be generated by development whilst recognising that the opportunity for on-site parking in many of the centres is limited.

Parking areas, accessways and servicing facilities must be designed carefully so that they do not detract from the appearance of the development or the streetscape and do not disrupt the continuity of the retail frontage or pedestrian movement.

This DCP does not permit access to a development site from the primary street in order to protect continuous active retail frontages. In those instances where there is no rear lane or side street access, this may restrict the potential for development that requires on-site parking or on-site loading facilities.

Note: Where there is any disparity between the objectives and performance criteria in NC DCP Part 5.9 and the provisions of Woollahra Parking DCP, the objectives and performance criteria of Part 5.9 take precedence.

Objectives

- 0 5.9.1** To ensure that developments generating vehicular traffic make adequate provision off the public street for the car parking and servicing needs of its occupants and users, including visitors, employees and deliveries.
- 0 5.9.2** To provide essential car parking and access while encouraging the use of public transport as well as walking and cycling.
- 0 5.9.3** To maximise retail frontage to primary streets.
- 0 5.9.4** To ensure that on-site car parking and driveways do not dominate or detract from the appearance of the development and the local streetscape.
- 0 5.9.5** To maximise pedestrian safety and amenity.
- 0 5.9.6** To encourage co-operative approaches to car parking provision between adjoining small lots, where car parks may be amalgamated and share access and egress points.
- 0 5.9.7** To ensure the safe and efficient movement of vehicles within, entering and leaving properties.

Performance criteria

- C 5.9.1** Development complies with the provisions of the Woollahra Parking DCP except for the requirements for residential parking spaces.
- C 5.9.2** Development provides the following number of on-site car parking spaces for the residential component of mixed-use development:
- | | | |
|-----|------------------|---------------------|
| for | 1 bedroom units | 1.0 space per unit |
| for | 2 bedroom units | 1.0 space per unit |
| for | 3+ bedroom units | 2.0 spaces per unit |
| for | visitors | 0.25 space per unit |
- C 5.9.3** Car parking and driveway areas are located and designed to:
- enable the efficient use of car spaces and accessways, including safe manoeuvrability for vehicles between the site and the street;
 - minimise disruption to pedestrian movement, safety, and amenity
 - preserve existing trees and vegetation; and
 - complement the desired future character for the precinct described in Part 4.
- C 5.9.4** Access to on-site car parking and servicing facilities is provided from rear lanes or secondary streets.
- C 5.9.5** Access to development is provided by one driveway only, and that driveway is between 3.5m and 6.0m wide.
- C 5.9.6** Access to on-site car parking and servicing facilities is designed perpendicular to the street alignment and does not ramp along a street or lane alignments.
- C 5.9.7** On-site parking areas are provided below ground where possible, and carparking is not located on any level above the ground level.
- C 5.9.8** On-site car parking areas are not visible from the main street frontage.
- C 5.9.9** Servicing facilities for non-residential uses are located and designed to protect the amenity of residents.
- C 5.9.10** Residential parking areas are secure and separate from non-residential vehicle parking and servicing areas.

- C 5.9.11** For the non-residential component of parking, stack parking may be permitted for long stay spaces only.
- C 5.9.12** For the residential component of parking, stack parking may be permitted only where two spaces are designated for a single dwelling.
- C 5.9.13** Car hoists, car lifts or mechanical stacking equipment are used only for access between ground and basement levels, and their use serves to reduce the impacts of development on street amenity and character.
- C 5.9.14** Facades screening car parks from the street are of high quality and allow natural lighting and ventilation.

Site excavation

- C 5.9.15** The area of site excavated for the purposes of underground carparking is limited to the building footprint of the development.
- C 5.9.16** Permanent sub-surface support and retention structures are set back a minimum of 900mm from adjacent property boundaries.

Note: Council may consider construction of new development to the boundary on a merit based assessment.

5.10 SITE FACILITIES

Explanation

Site facilities include:

- mail boxes;
- garbage collection areas;
- external storage areas;
- basement storage areas;
- clothes drying areas;
- laundry facilities;
- television antennae;
- radio transmitters and aerials; and
- satellite dishes.

The potential impacts of site facilities on the overall appearance of developments and the centres need to be considered.

Domestic incinerators are not permitted in the Municipality of Woollahra due to their deleterious impact on air quality and potential to contribute to the build up of greenhouse gases.

Objectives

- O 5.10.1** To ensure that adequate provision is made for essential site facilities, such as laundries, clothes lines and garbage receptacles.
- O 5.10.2** To ensure that the essential site facilities are functional and accessible to all premises and are easy to maintain.
- O 5.10.3** To ensure that site facilities are thoughtfully integrated into development and are unobtrusive.

Performance criteria

- C 5.10.1** Mail boxes are centrally located and intergrated with the major building entry, and are lockable.
- C 5.10.2** Lockable storage space of at least 8.0m³ per dwelling is provided.

C 5.10.3 Development incorporates adequate garbage and recycling collection areas which are integrated physically and visually with other built elements such as fences, walls, buildings and garages.

Note: Information relating to specific requirements for garbage and recycling is contained in Annexure 10 of Council's DA Guide. This note does not form part of the approved DCP, but is provided for guidance.

C 5.10.4 Fencing, landscaping and roof treatments are used to screen garbage and recycling areas.

C 5.10.5 Garbage and recycling areas are located away from windows and doors in the least visually obtrusive positions.

C 5.10.6 Mixed use buildings have only one common television antennae which is not visually intrusive to the streetscape.

C 5.10.7 Satellite dishes, radio transmitters and aerials:

- are not visually intrusive to the streetscape;
- are located in positions that have a minimal impact on the amenity of adjoining properties and neighbouring lands;
- do not have a negative impact on the architectural character of the building to which they are attached.

C 5.10.8 Buildings are designed to accommodate venting from ground floor uses, to avoid potential impacts from exhaust and odour, such as cooking smells.

C 5.10.9 Any development which includes a residential component must provide laundry facilities, and at least one external drying area. The public visibility of this area must be minimised

5.11

ADVERTISING

SIGNAGE AND

ILLUMINATION

Explanation

Signage and advertising needs to communicate effectively and make a positive contribution to the public domain. Signage in the centres should generally be integrated with the design of buildings and be compatible with the desired streetscape character.

Objectives

- 0 5.11.1** To ensure that signage and advertising is compatible with both the architectural design of buildings and the existing or desired future street character.
- 0 5.11.2** To promote signage that assists in wayfinding and pedestrian useability.
- 0 5.11.3** To ensure that the location and design of signs is consistent with road safety and traffic management principles.
- 0 5.11.4** To protect the visual quality of the public domain and the amenity of residential development in the assessment of signage.
- 0 5.11.5** To prevent adverse impacts on the streetscape and local amenity from excessive advertising and illumination of shopfronts in general, and convenience stores in particular.
- 0 5.11.6** To preserve existing and future roofscapes and to protect views.

Performance criteria

- C 5.11.1** Signage achieves a high degree of integration with the architectural design of the supporting building having regard to its composition, fenestration, materials, finishes and colours and does not obscure its architectural features.
- C 5.11.2** The main facade of the building between the first floor and the parapet line is free of signage except for an approved building identification sign.
- C 5.11.3** A building identification sign, if required, is composed of individual affixed letters and/or numbers.
- C 5.11.4** Where possible, signage is primarily located on the awning fascia and under the awning .
- C 5.11.5** Development does not include signs painted on, applied to, or fixed to a roof.

- C 5.11.6** Development does not include animated or flashing signs.
- C 5.11.7** The use of any corporate colours, logos and graphics is highly compatible with the architecture, materials, finishes and colours of the building and does not have an adverse impact on the character of the streetscape.
- C 5.11.8** Signage does not contain advertising promoting products or services other than those included in the approved use of the site.
- C 5.11.9** A coordinated scheme for all signs is provided where there are multiple occupancies or uses within a single building development or site.
- C 5.11.10** Illuminated signage does not have an adverse impact on the amenity of residential buildings.
- C 5.11.11** Advertising signs are not located on a public footpath.
- C 5.11.12** Advertising signs do not face a service lane, and are not located on a side wall abutting a residential property.
- C 5.11.13** Signage is constructed of non-combustible materials.
- C 5.11.14** Electrical conduits to illuminated signs are concealed or are integral to the sign.
- C 5.11.15** The total signage area does not exceed a factor of 0.5 square metres for each metre of the building width at its frontage to a public road.
- C 5.11.16** Servicing and delivery signs do not exceed an area of 0.35m².
- C 5.11.17** Freestanding signs do not exceed a height of 5m and an area of 7.5m².
- C 5.11.18** Illumination from a convenience store does not exceed a maximum horizontal illuminance of 200 lux.
- C 5.11.19** Signage for convenience stores does not include neon tubes or fluorescent lighting (located either externally or in a shopfront window), banners, flags or spotlights.
- C 5.11.20** The assessment of new signage must also have regard to:
 - (i) the number of existing signs on the site and within its vicinity,
 - (ii) whether the cumulative impact of signage causes visual clutter.

5.12
ACCESS AND
MOBILITY

Explanation

Access and mobility provisions aim to promote the social welfare of the community through the provision of accessible and adaptable housing as well as improved access for the aged and disabled to new developments and public areas. The Disability Discrimination Act (DDA) 1992 makes it unlawful to discriminate against people with disabilities in all areas of public life, including access to, and the use of, buildings and places.

The provisions of the Access DCP (2004) provide guidance to developers on the access requirements for development in Neighbourhood Centres. The provisions encourage adaptable and accessible housing as well as building modifications to provide visitation by persons with a disability. Certain access provisions are to be made for certain types of development as outlined in Table 1 of the Access DCP.

Objectives

- O 5.12.1** To encourage new buildings and associated spaces to be accessible and useable by all people in the community, including people with disabilities.
- O 5.12.2** To create appropriate levels of access when alterations and additions are proposed to existing buildings, including existing commercial buildings.
- O 5.12.3** To promote sustainable development by extending the use of new and existing buildings through the provision of accessible and adaptable housing requirements and by increasing the number of accessible and adaptable houses in the Municipality.
- O 5.12.4** To ensure that housing options exist for people with a disability as prescribed by the BCA through the provision of accessible and adaptable housing;
- O 5.12.5** To provide adequate access for people with a disability to disabled car parking, footpaths, bus stops, bus shelters, public toilets, parks and other infrastructure and outdoor areas;

Performance criteria

- C 5.12.1** Development is to comply with the provisions of the Access DCP (2004).

Explanation

Outdoor eating facilities on footpaths or in public places have the potential to add to the liveliness of streets and activate the public domain. A number of the neighbourhood centres have suitable conditions for outdoor dining, including temperate climate, favourable orientation, leafy ambience, and adequate footpath width.

Council would encourage eating establishments where they provide a pleasant outdoor eating environment, cause minimal disturbance to pedestrian circulation and where they comply with Council's requirements for footpath restaurants, which are contained in the 'Footpath Restaurant Code'.

5.13**FOOTPATH DINING**

Fig 5.24
Outdoor eating in
Bellevue Road

5.14
LANDSCAPED
OPEN SPACE

Explanation

Landscaped open space within developments may comprise both communal and private open space areas. Landscape treatment helps to determine the amenity of individual dwellings, define private and public areas, reinforce or screen views and define local character. The amount and composition of landscaped open space also play important roles in stormwater management, the energy efficiency of developments and access to sunlight.

Private open space may be provided at ground or above ground level. Refer to *Section 5.4: Building Articulation* for controls for above ground private open space.

Objectives

- O 5.14.1** To ensure the adequate provision of accessible and useable private and communal open space.
- O 5.14.2** To retain important existing mature trees, vegetation and other landscape features.
- O 5.14.3** To enhance the appearance, amenity and energy efficiency of housing through integrated landscape design.
- O 5.14.4** To enhance stormwater management.

Performance criterion

- C 5.14.1** Deep soil landscape area must comprise at least 10% of the site area.
- C 5.14.2** Part of the private open space is capable of serving as an extension of the dwelling and is directly accessible from the main living area of the dwelling.
- C 5.14.3** Existing significant tree and vegetation are incorporated into proposed landscape treatment.
- C 5.14.4** Wherever possible car parking is located under the building footprint to maximise deep soil landscaping.
- C 5.14.5** Development provides a minimum of 500mm of soil above underground carparking areas to allow sustainable planting.

Explanation

The development of telecommunications and radiocommunications facilities in recent years has produced some significant benefits to the community. Examples of these include: better communications in the emergency services field; better business opportunities and the advent of mobile telephony.

It has also led to the proliferation of base stations and supporting infrastructure in the community. This has resulted in considerable community concern regarding the effects of this infrastructure on the visual amenity of the locality, property values and the potential health risks from electromagnetic radiation (EMR).

Communities concerned about the installation of telecommunications infrastructure have supported local government policies to protect their interests by requesting that infrastructure is sited in a precautionary manner. Consequently, several Councils developed a model Telecommunications and Radiocommunications DCP. This plan has been prepared based on the model DCP in order to offer a consistent approach to the processing and assessment of Development Applications for the location and siting of telecommunications and radiocommunications facilities.

All facilities are required to comply with the mandated Australian Standard for maximum EMR exposure. Local government has requested the Commonwealth Government and industry to adequately protect public health from all potential effects of EMR. Non-heating effects have been reported in a large number of scientific papers but no consensus of proof has been reached. The World Health Organisation notes from its 1996 review that "from the current scientific literature, there is no convincing evidence that exposure to radiofrequency shortens the lifespan to humans, induces or promotes cancer but stressed that "further studies are needed to draw a more complete picture of health risks, especially about possible cancer risk from exposure to low levels of radiofrequency exposure".

Under Commonwealth legislation, the Telecommunications (Low-impact Facilities) Determination 1997 (LIF Determination) precludes Councils from having any approval or consent powers for 'low-impact' facilities including most mobile telephone base stations. Structures classified as 'not low-impact' facilities are subject to obtaining development consent from Council and will be assessed against the provisions of the Telecommunications and Radiocommunications DCP (2004). The DCP also provides guidelines to telecommunications carriers for the construction and installation of 'low-impact' facilities

Objectives

- O 5.15.1** To provide a consistent and integrated planning framework that addresses the community's interests in the effective and efficient provision of telecommunications and radiocommunications infrastructure so that it achieves environmental, economic and social sustainability in the short, medium and long term.
- O 5.15.2** To provide a consistent approach which benefits carriers, community and councils.
- O 5.15.3** To balance the needs of different stakeholders, including the community, industry, local, state and federal governments.
- O 5.15.4** To provide guidance to carriers about council's requirements for:
 - site selection
 - lodging an application
 - conducting community consultation.

Performance criteria

- C 5.15.1** Development is to comply with the provisions of the Telecommunications and Radiocommunication DCP (2004).

PART

6

Definitions

PART 6

Ancillary development	means a building or structure, other than a dwelling house, dual occupancy, mixed development, residential flat building or other housing type, but including sheds, pool houses, detached garages, gazebos, separate laundries, pagodas, swimming pools and pergolas.
Attic level	means a room or rooms contained within the roof space under the beams of the roof where the roof of the building pitches from the ceiling level of the uppermost floor.
Balcony	means a raised platform added to the enclosing envelope of a building and unenclosed except for the external enclosing walls of the building and/or an approved balustrade or privacy screen.
Biodiversity	in broad terms, refers to "the variety of life forms, the different plants, animals and microorganisms, the genes they contain and the ecosystems they form" (NPWS 1997). Biodiversity impacted upon by housing development may range from local animal and plant populations affected by site development through to other life forms affected by broader activities such as pollution, global warming and land clearance.
Boat shed	means a building or any other structure used for the storage and routine maintenance of a boat or boats and which is associated with a private residence and includes any skid used in connection with the building or other structure.
Building footprint	means the area of land measured at finished ground level, which contains all external walls and balconies of a dwelling house, dual occupancy or residential flat building including all above ground levels.
Building line	means the street addressing wall of a dwelling house, dual occupancy or residential flat building (not including forward projections accommodating car parking and the like).
Cafe	see definition of 'restaurant'
Communal open space	means useable shared open space for the recreation and relaxation of residents of a housing development and which is under the control of a body corporate or equivalent.
Communal street	means the carriageway providing access to a housing development and which is under the control of a body corporate or equivalent.
Contributory building	means a building of some architectural or historical merit that contributes to the overall character of the area.

Deep soil (landscape) zone means that area of landscape open space within a site with no above ground, ground level or subterranean development. Paved surfaces, driveways, pathways, swimming pools or tennis courts do not constitute deep soil landscape area.

Desired future character objective

describes an outcome that, where relevant, development is required to achieve for a given precinct in Part 4 of the NC DCP. Desired future character objectives describe the intent of precinct-specific performance criteria and are also intended to fulfil the objectives of the NC DCP listed in Section 1.5.

Development control plan (DCP)

means a plan made by either Council or under section 72 or section 51A of the Environmental Planning and Assessment Act 1979 respectively. DCPs are used to provide more detailed provisions than those included in a local environmental plan (in the case of a DCP made by a Council) or a regional environmental plan (in the case of a DCP made by the Department of Planning).

Dual occupancy

means two dwellings on a single allotment of land in the form of either a) one building containing two dwellings and known as an 'attached dual occupancy'; or b) two separate buildings comprising an 'ancillary dwelling' and a 'principal dwelling', collectively known as a 'detached dual occupancy'.

Dwelling

means a room or suite of rooms occupied or used or so constructed or adapted to be capable of being occupied or used as a separate domicile.

Dwelling house

means a building containing one but not more than one dwelling on one allotment of land.

Ecologically sustainable development

defined by the National Strategy for Ecologically Sustainable Development as "development that uses, conserves and enhances the community's resources so that ecological processes, on which life depends, are maintained and the total quality of life now and in the future can be increased".

ESD encompasses objectives of energy efficiency, the minimisation of greenhouse gas emissions, the efficient use of land and resources, the conservation of biodiversity and equity within and between generations.

Underpinning ESD is the 'precautionary principle'. This means that a lack of full knowledge about the future impacts of a proposed development should not be used as an excuse to postpone action to prevent environmental degradation.

Existing ground level means the surveyed level of the ground surface immediately prior to the proposed development and prior to any associated excavation, development or site works.

Explanation in relation to Part 5 of the NC DCP, refers to background information on a given topic to assist applicants in interpreting objectives and performance criteria included in the NC DCP's General Controls. The explanation is designed to assist applicants in determining how objectives and performance criteria should be applied to their development proposal.

Floor space elements in relation to a building, means elements that are included in the calculation of gross floor area.

Floor space ratio in relation to a building, means the ratio of the gross floor area of the building to the site area of the land on which the building is or is proposed to be erected.

Foreshore the section of land extending from the low water mark to the rear of the first line of properties as viewed from the waterway.

Foreshore building line area means the area of land between the foreshore building line and the waters of Port Jackson.

Front fences and walls refers to fences and walls located or proposed to be located forward of the building facade.

Frontage means the alignment at the public road reserve at the front of a lot and in the case of a lot that abuts two or more streets, it means the alignment at the primary street.

Greenhouse gases refer to atmospheric gases resulting from human influence. The increased concentration of greenhouse gases in the Earth's atmosphere is believed to contribute to the 'Greenhouse Effect', a gradual warming of the Earth's climate caused by a depletion in atmospheric ozone and a declining ability to reflect the Sun's radiation.

Major greenhouse gases and their causes include carbon dioxide, methane, chloroflourocarbons, nitrous oxides and ozone. Activities

	<p>in the Woollahra Municipality that are likely to emit such gases include those involving the combustion of fuels, such as vehicle use and the burning of timber (solid fuel), clearance of vegetation and the processing of waste.</p>
Gross floor area	<p>in relation to a building, means the sum of the areas of each level of the building, including:</p> <ul style="list-style-type: none"> (a) the thickness of all external walls; and (b) the area of voids, staircases, and lift shafts, counted at each level; and (c) that part of the area of balconies and verandas which is in excess of 20m² per dwelling in the case of a building used or intended for use for residential purposes, or in excess of 10% of the site area in the case of a building used or intended for use for non-residential purposes; and (d) any other areas of the building where the height of those areas exceeds 1.5 metres above ground level; and excluding - (e) car parking to meet the requirements of the Council and any vehicular access thereto; and (f) any area used or intended for use as a car parking station; and (g) uncovered roof terraces; and (h) any area used or intended for use as an arcade.
Habitable room	<p>means a room in a dwelling used for normal domestic activities that includes:</p> <p>a bedroom, living room, lounge room, music room, television room, kitchen, dining room, sewing room, study, playroom and sunroom;</p> <p>but excludes:</p> <p>a bathroom, laundry, water closet, food storage pantry, walk-in wardrobe, corridor, hallway, lobby, photographic darkroom, clothes drying room and other spaces of a specialised nature occupied neither frequently nor for extended periods.</p>
Height	<p>in relation to a building means the greatest distance measured vertically from any point on the building to the existing ground level immediately below that point.</p>

Important character elements

refer to the aspects of a given precinct described in Part 4 of the NC DCP that, where appropriate, are required to be preserved or enhanced by a proposed development.

Inter-war flat building

means a building of two storeys or more and containing two or more dwellings, constructed in the period from c.1918 to c.1950.

Jetty

means a horizontal decked walkway on piered or piled foundation, providing access from the shore to the waterway.

Landscaped open space

means any areas that is landscaped by way of planting of gardens, lawns, shrubs or trees but does not include that part of the site used for driveways and parking, a swimming pool or tennis court.

Local environmental plan (LEP)

means a plan made under section 70 of the Environmental Planning and Assessment Act 1979. An LEP is a legal document and generally provides the land use zones, Council objectives and development standards for different types of development.

Lot width

at any given point on a site, means the distance measured along a straight line between the side boundaries of an allotment and parallel to the street frontage.

Mixed development

means one or more dwellings (or a boarding house) within the same building as, or on the same allotment of land as, shops, commercial premises or any other non-residential use which is not prohibited in the zone.

NatHERS or equivalent

NatHERS (Nationwide House Energy Rating System) is a computer simulation tool developed by the CSIRO for rating the thermal performance of houses across Australia. The Energy Management Task Force is responsible for delivering a NatHERS compliance protocol. Any software or paper checklist which passes under this protocol is deemed "NatHERS or equivalent" (SEDA 1997).

North facing

means the orientation range within 20° west and 30° east of true solar north.

Objective

describes an outcome that development is required to achieve in relation to the Part 4 and 5 of this NC DCP. Objectives describe the intent of the related performance criteria and are also intended to fulfil the objectives of the NC DCP listed in Section 1.5.

Occupiable area	means the maximum proportion of potential plan area per floor permitted to be built as floor space elements or non-floor space elements. For example '50% occupiable area' means that no more than half of the maximum possible floor plate on each level is to be occupied by floor and non-floor space elements.
Performance criteria	represent specific ways in which a proposed development can meet the related objectives listed in Parts 4 and 5 of the NC DCP. The relevance and intent of a specific performance criterion in relation to a proposed development must be interpreted in the context of the related objective.
Private open space	means an area of land or of a building (such as a balcony or uncovered roof terrace) belonging to a dwelling and intended for the exclusive use of the occupants of the dwelling and located and designed so as to offer visual privacy to the occupants. Private open space provided at above ground level must be located a minimum of 2m above ground level. Note: For the purpose of calculating the area of private open space to be provided, tennis courts, swimming pools and spa pools are not included as private open space.
Public domain	refers to the community's shared spaces, the structures that relate to those spaces and the infrastructure that supports and serves them (Prime Minister's Urban Design Task Force 1994, p. 6). The public domain includes streets, footpaths, squares and public open spaces, as well as items such as street trees, street furniture, lighting and drainage. The design of buildings and works on private land can entail significant implications for the public domain. For example, building form and location may affect the availability of public views, street shading, neighbourhood surveillance and visual amenity. At the same time, a high quality public domain can substantially add to the attractiveness and value of private houses.
Public open space	means land used or intended for use for recreational purposes by the public and includes parks, public gardens, riverside reserves, pedestrian and cyclist accessways, playgrounds and sports grounds.
Regional environmental plan (REP)	means a plan made under Section 51 of the Environmental Planning and Assessment Act 1979. REPs refer to environmental planning matters which are considered by the Minister to be of significance

for a region (or part of a region). The meaning of what constitutes a region for the purposes of an REP depends on the circumstances and the nature of the issues addressed. For example, Sydney Harbour is defined as a "region" by Sydney REP 23 - Sydney and Middle Harbours.

Residential flat building means a building containing two or more dwellings, but does not include a building specifically defined elsewhere in the Woollahra LEP 1995 (as amended).

Restaurant means a building or place, the principal purpose of which is the provision of food or beverages to people for consumption on the premises and that may also provide takeaway meals. As such, 'restaurant' also includes cafe and refreshment room activities.

Seawall means a structure placed partially or wholly along the land/water interface to protect the land from the sea or to stop accelerated erosion of the shoreline, but does not include a breakwater.

Setback means the horizontal distance between a building and a site boundary, measured along a line perpendicular to the site boundary. The building includes all parts of the building from the lowest point (including where it extends below ground level) to its highest point.

Site means the allotment or group of allotments of land on which a building stands or is proposed to be erected.

Solar access means the amount of direct access to sunlight enjoyed by a building, room or open space.

Solar passive design means dwelling design which combines the sun's energy with local climate characteristics to achieve comfortable temperatures without the use of mechanical devices.

Spa pool means an impermeable structure capable of holding water to a depth greater than 300mm generally used for recreation purposes and includes hot tubs and other like structures, but does not include a swimming pool.

Storey means any separate level within a building (not including levels below existing ground level provided for car parking or storage, or both, that protrude less than 1.2m above existing ground level, or an attic level.).

In determining the number of storeys which a building contains, the number shall be deemed to be the maximum number of storeys, floors or levels of a building which may be intersected by the same vertical line, not being a line which passes through any wall of the building.

Street alignment	means the horizontal shape of the street reserve boundary.
Streetscape	refers to the collection of visible elements in a street, including the form and treatment of buildings, setbacks, fences and walls, landscaping and trees, driveway and street layout and surfaces, utility services and street furniture such as lighting, signs, barriers and bus shelters.
Swimming pool	means an impermeable structure capable of holding water to a depth greater than 300mm for swimming or other recreation purposes, but does not include a spa pool.
Thermal mass	refers to the ability of buildings and materials to store heat, principally from the sun. Materials with good thermal mass include brick, concrete, mud brick, rammed earth and stone.
Tree	means a long lived woody perennial plant greater than (or potentially greater than) 5m in height or having a dimension greater than 3m in width with one or relatively few stems.
Uncovered roof terrace	means the flat roof of a building (or part thereof), which is designed to be used (or capable of being used) for the purpose of open space or recreation, and is open to the sky except for a pergola or similar non-continuous shade device.
Wall height	means the greatest distance measured vertically from the topmost point on an external wall of a building, other than a gable wall or the wall of a dormer window, to the existing ground level immediately below that point.